

Table of Contents

Part I : Technical Information	2
1. Summary	2
2. Specifications	3
2.1 Specification Sheet.....	3
3. Outline Dimension Diagram	7
4. Refrigerant System Diagram	8
5. Electrical Part	9
5.1 Wiring Diagram	9
5.2 PCB Printed Diagram	11
6. Function and Control	13
6.1 Remote Controller Introduction	13
6.2 Brief Description of Models and Functions	18
7. Notes for Installation and Maintenance	20
Part II : Installation and Maintenance	20
8. Installation	25
8.1 Installation Dimension Diagram.....	25
8.2 Preparative for Installation	26
8.3 Installation of Cassette Type.....	27
8.4 Installation of the Connection Pipe	28
8.5 Installation of the Drain Hose	30
8.6 Installing the Front Panel	32
8.7 Electrical Wiring.....	32
8.8 Installation of Controrllers.....	33
8.9 Test Running.....	33

9. Maintenance 34

- 9.1 Error Code List.....34
- 9.2 Procedure of Troubleshooting35
- 9.3 Troubleshooting for Normal Malfunction41

10. Exploded View and Parts List..... 43

11. Removal Procedure 47

Appendix 51

- Appendix 1: Reference Sheet of Celsius and Fahrenheit.....51
- Appendix 2: Configuration of Connection Pipe51
- Appendix 3: Pipe Expanding Method.....52
- Appendix 4: List of Resistance for Temperature Sensor.....53

1. Summary

Indoor Unit:

CHML-IC12RK2
CHML-IC18RK2



CHML-IC24RK2



Remote Controller:

YAP1F7(WiFi)



2. Specifications

2.1 Specification Sheet

Model			CHML-IC12RK2
Product Code			CN510N0290
Power Supply	Rated Voltage	V~	220-240
	Rated Frequency	Hz	50
	Phases	-	1
Cooling Capacity		KW	3.50
Heating Capacity		KW	4.00
Air flow volume		m ³ /h	560/540/490/450/420/380/350
Dehumidifying Volume		L/h	1.4
Fan Type			Centrifugal
Fan Diameter-height		mm	Φ315-162.5
Fan Motor Cooling Speed		rpm	700/660/600/560/520/480/440
Fan Motor Heating Speed		rpm	700/660/600/560/520/480/440
Fan Motor Power Output		W	30
Fan Motor Power Input		W	/
Fan motor running current		A	/
Fan Motor Capacitor		μF	/
Evaporator Material			Inner Groove Copper Tube-Aluminum fin
Evaporator Pipe Diameter		mm	Φ7
Evaporator Number of Rows-Fin Pitch		mm	2- 1.6
Evaporator Length(L)XHeight(H)XWidth(W)		mm	1176X228.6X25.4
Fuse Current		A	3.15
Sound Pressure Level		dB (A)	Cooling:41/39/36/34/32/30/28 Heating:40/38/36/34/32/30/28
Sound Power Level		dB (A)	57/55/52/50/48/46/44
Dimension of Outline(LXDXH)		mm	570X570X265
Dimension of Carton Box(LXWXH)		mm	695X650X280
Dimension of Package(LXWXH)		mm	698X653X295
Net Weight		kg	17.0
Gross Weight		kg	22.0
Liquid pipe		inch	1/4"
Gas Pipe(to indoor unit)		inch	3/8"

The above data is subject to change without notice. Please refer to the nameplate of the unit.

2. Specifications

Model		CHML-IC18RK2
Product Code		CN510N0280
Power Supply	Rated Voltage	V~ 220-240
	Rated Frequency	Hz 50
	Phases	- 1
Cooling Capacity	KW	5.00
Heating Capacity	KW	5.50
Air flow volume	m ³ /h	650/540/490/450/420/380/350
Dehumidifying Volume	L/h	1.8
Fan Type	-	Centrifugal
Fan Diameter-height	mm	Φ315-162.5
Fan Motor Cooling Speed	rpm	780/660/600/560/520/480/440
Fan Motor Heating Speed	rpm	780/660/600/560/520/480/440
Fan Motor Power Output	W	30
Fan Motor Power Input	W	/
Fan motor running current	A	/
Fan Motor Capacitor	μF	/
Evaporator Material	-	Inner Groove Copper Tube-Aluminum fin
Evaporator Pipe Diameter	mm	Φ7
Evaporator Number of Rows-Fin Pitch	mm	2- 1.6
Evaporator Length(L)XHeight(H)XWidth(W)	mm	1176X228.6X25.4
Fuse Current	A	3.15
Sound Pressure Level	dB (A)	Cooling:43/39/36/34/32/30/28 Heating:43/39/36/34/32/30/28
Sound Power Level	dB (A)	59/55/52/50/48/46/44
Dimension of Outline(LXDXH)	mm	570X570X265
Dimension of Carton Box(LXWXH)	mm	695X650X280
Dimension of Package(LXWXH)	mm	698X653X295
Net Weight	kg	17.0
Gross Weight	kg	22.0
Liquid pipe	inch	1/4"
Gas Pipe(to indoor unit)	inch	1/2"

The above data is subject to change without notice. Please refer to the nameplate of the unit.

2. Specifications

Model		CHML-IC24RK2
Product Code		CN510N0300
Power Supply	Rated Voltage	V~ 220-240
	Rated Frequency	Hz 50
	Phases	- 1
Cooling Capacity	KW	7.00
Heating Capacity	KW	8.00
Air flow volume	m ³ /h	1100/1050/950/910870//830/800
Dehumidifying Volume	L/h	2.5
Fan Type	-	Centrifugal
Fan Diameter-height	mm	Φ478.4-134
Fan Motor Cooling Speed	rpm	560/540/520/500/480/460/440
Fan Motor Heating Speed	rpm	560/540/520/500/480/460/440
Fan Motor Power Output	W	35
Fan Motor Power Input	W	/
Fan motor running current	A	/
Fan Motor Capacitor	μF	/
Evaporator Material	-	Inner Groove Copper Tube-Aluminum fin
Evaporator Pipe Diameter	mm	Φ7
Evaporator Number of Rows-Fin Pitch	mm	2- 1.6
Evaporator Length(L)XHeight(H)XWidth(W)	mm	2021X190.5X25.4
Fuse Current	A	5
Sound Pressure Level	dB (A)	Cooling:44/43/42/40/39/38/37 Heating:46/45/44/43/42/41/39
Sound Power Level	dB (A)	32/61/60/59/58/57/55
Dimension of Outline(LXDXH)	mm	840X840X240
Dimension of Carton Box(LXWXH)	mm	960X960X310
Dimension of Package(LXWXH)	mm	963X963X325
Net Weight	kg	29.0
Gross Weight	kg	36.0
Liquid pipe	inch	1/4"
Gas Pipe(to indoor unit)	inch	5/8"

The above data is subject to change without notice. Please refer to the nameplate of the unit.

2. Specifications

Note: Nominal capacities are based on the follow conditions.

Mode	Indoor °C(°F)	Outdoor °C(°F)
Cooling	DB:27 (80.6)	DB:35(95)
	WB:19 (66.2)	WB:24(75.2)
Heating	DB:20 (68)	DB:7(44.6)
	WB:--(--)	WB:6 (42.8)
Piping Length	5m	

The air volume is measured at the relevant standard external static pressure.

Noise is tested in the semianechoic room, so it should be slightly higher in the actual operation due to environmental change.

3. Outline Dimension Diagram

CHML-IC12RK2 CHML-IC18RK2

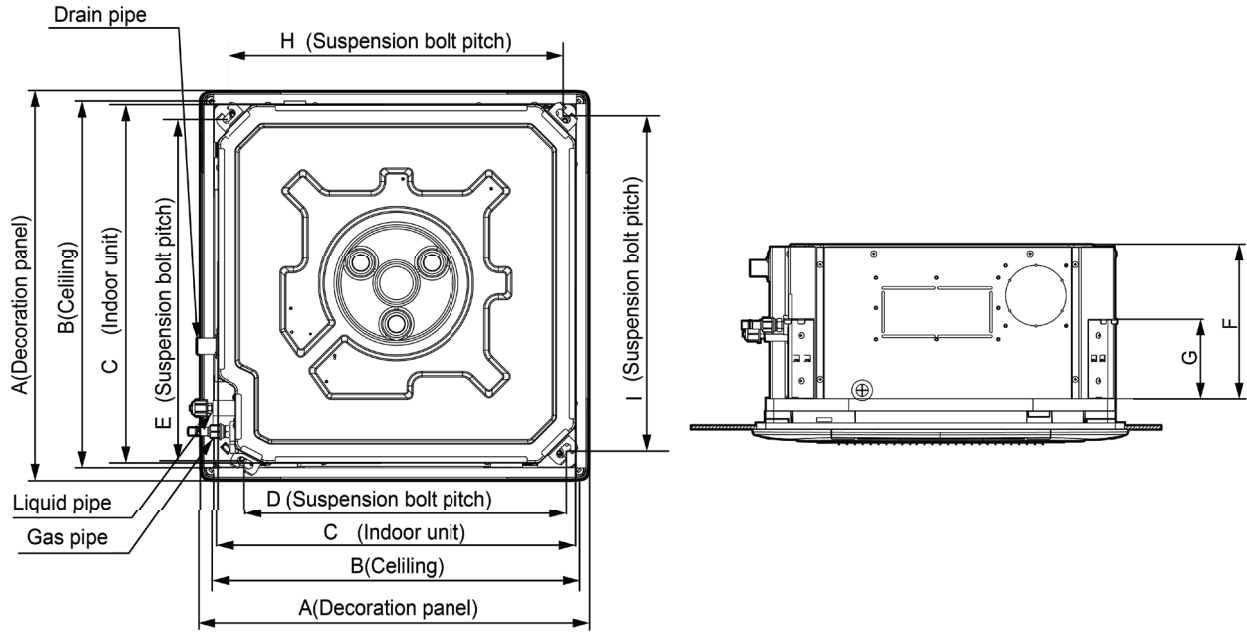

Unit: mm

Model	A	B	C	D	E	F	G	H	I
CHML-IC12RK2	620	580	570	505	550	265	140	530	530
CHML-IC18RK2	620	580	570	505	550	265	140	530	530

CHML-IC24RK2

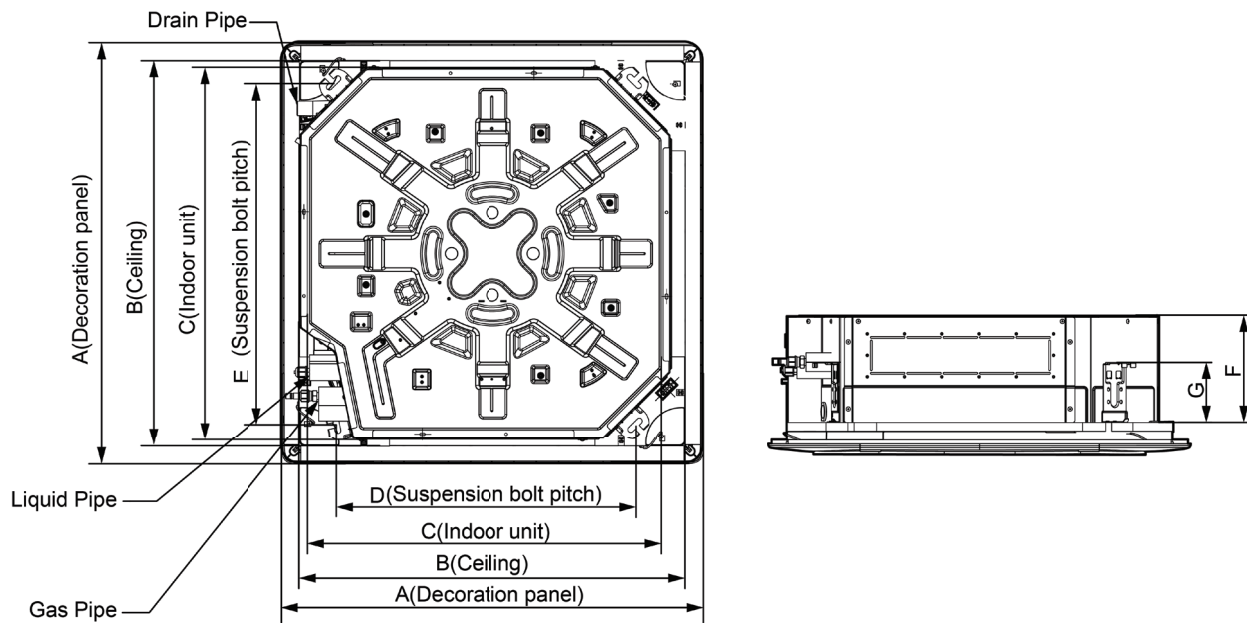

Unit: mm

Model	A	B	C	D	E	F	G
CHML-IC24RK2	950	870	840	680	780	240	135

4. Refrigerant System Diagram

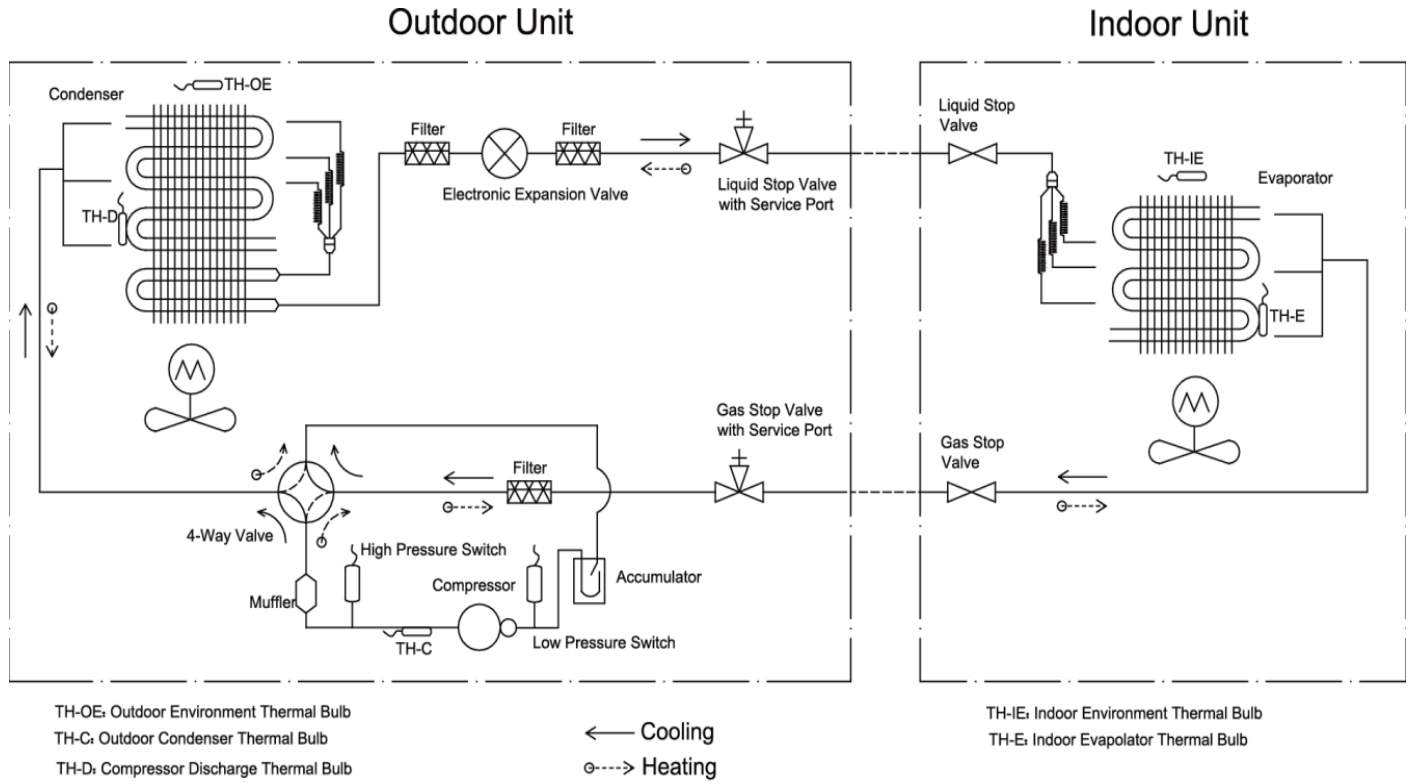

5. Electrical Part

5.1 Wiring Diagram

•Instruction

Symbol	Symbol Color	Symbol	Symbol Color	Symbol	Name
WH	White	GN	Green	CAP	Jumper cap
YE	Yellow	BN	Brown	COMP	Compressor
RD	Red	BU	Blue		Grounding wire
YEGN	Yellow/Green	BK	Black	/	/
VT	Violet	OG	Orange	/	/

Note: Jumper cap is used to determine fan speed and the swing angle of horizontal lever for this model.

CHML-IC12RK2 CHML-IC18RK2

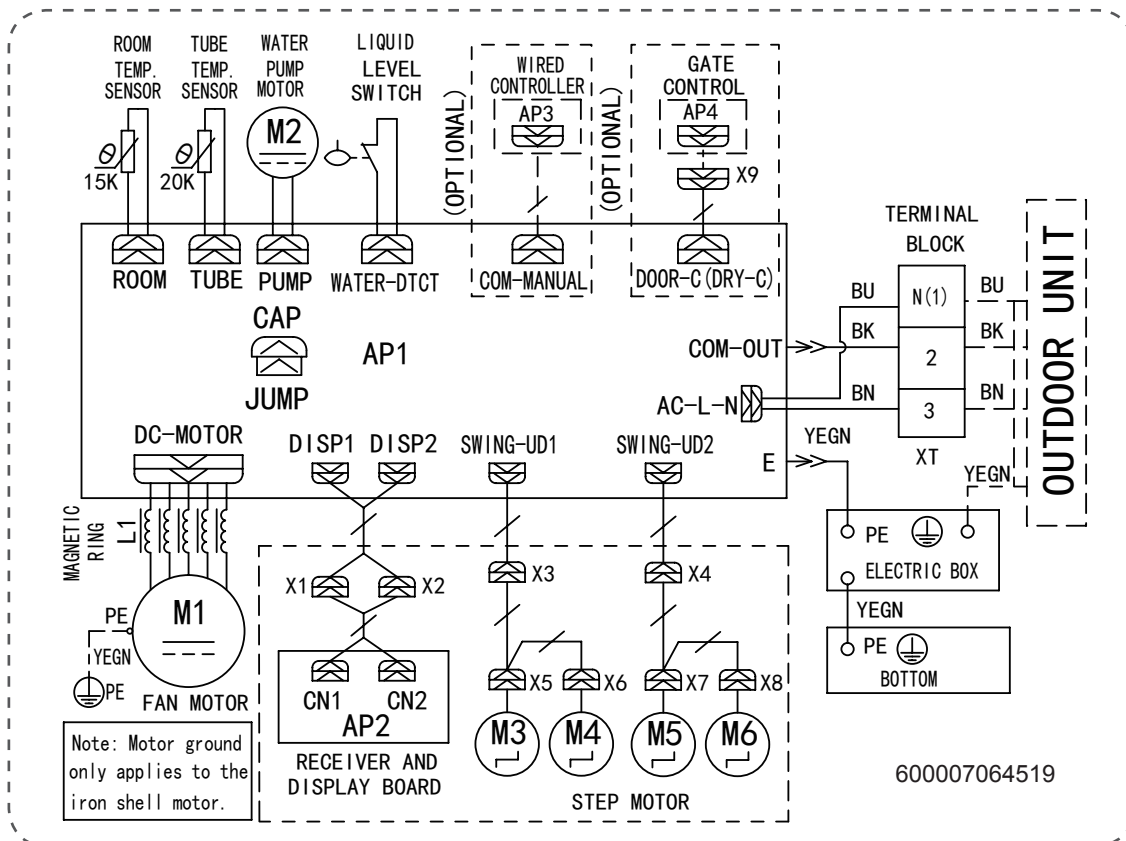

5. Electrical Part

CHML-IC24RK2

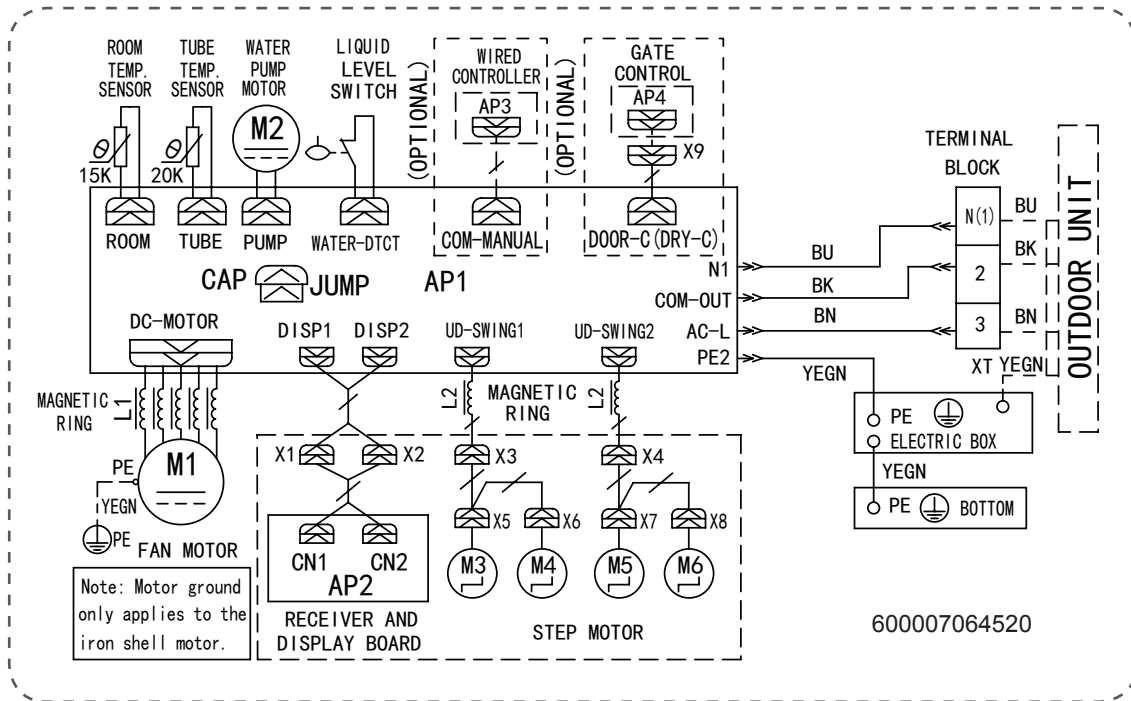

These wiring diagrams are subject to change without notice; please refer to the one supplied with the unit.

5. Electrical Part

5.2 PCB Printed Diagram

CHML-IC12RK2 CHML-IC18RK2

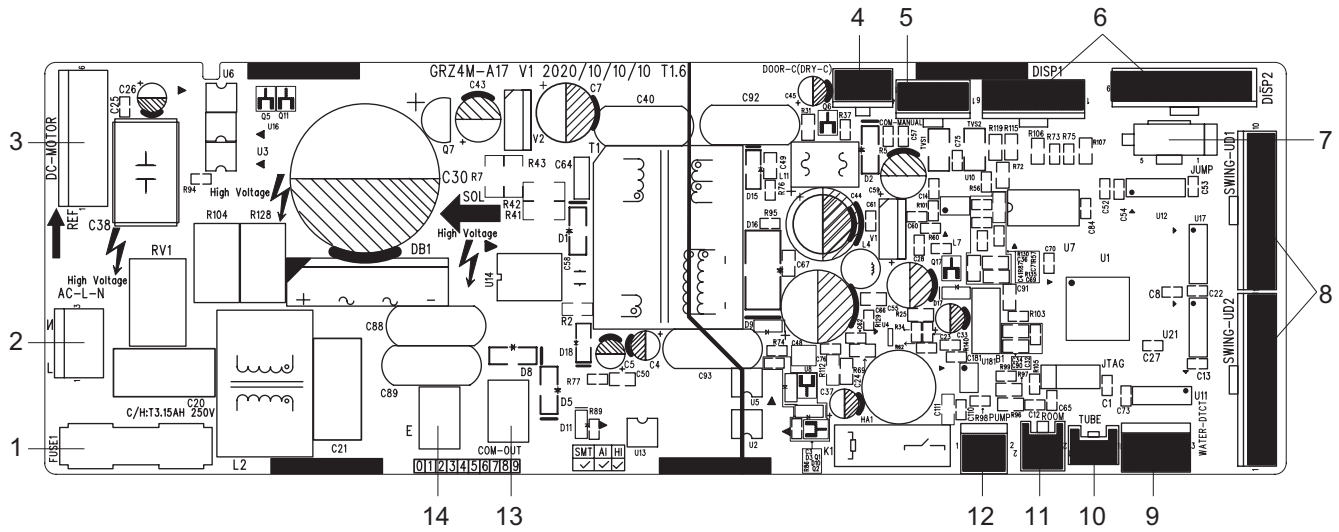

No.	Name
1	Fuse
2	Interface of live and neutral wire
3	Interface of fan
4	Interface of gate-control detection
5	Wired controller
6	Display interface
7	Jump cap

No.	Name
8	Up&down swing terminal
9	Water full detection terminal
10	Interface of tube temperature sensor
11	Interface of ambient temperature sensor
12	Water pump control
13	Terminal with outdoor unit communication wire
14	Ground wire interface

5. Electrical Part

CHML-IC24RK2

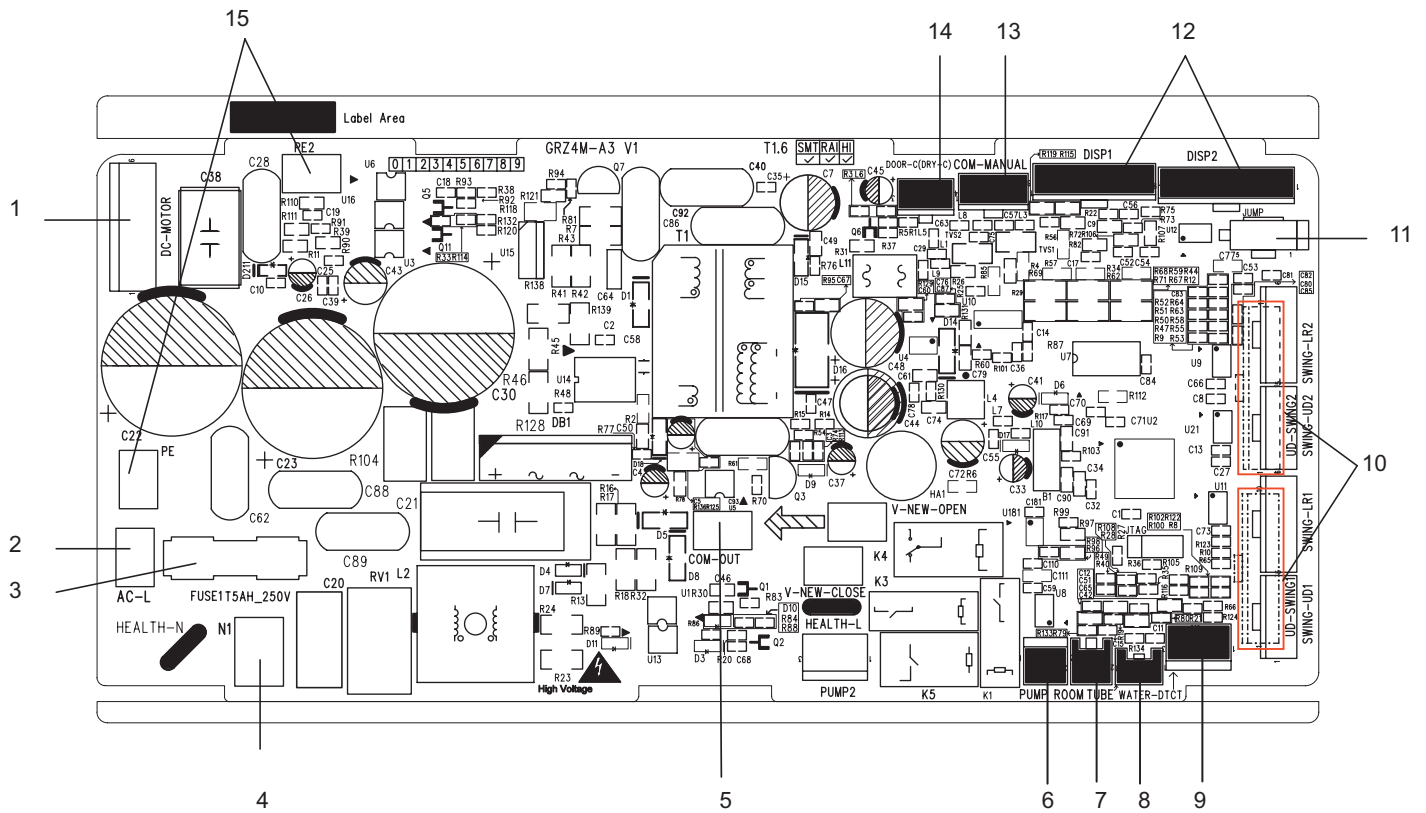

No.	Name
1	Interface of fan
2	Interface of live wire
3	Fuse
4	Interface of netural wire
5	Terminal with outdoor unit communication wire
6	Water pump control
7	Interface of ambient temperature sensor
8	Interface of tube temperature sensor

No.	Name
9	Water full detection terminal
10	Up&down swing terminal
11	Jumper cap terminal
12	Display interface
13	Wired controller
14	Interface of gate-control detection
15	Grounding wire

6. Function and Control

6.1 Remote Controller Introduction

NOTE:

- This is a general use remote controller. It could be used for the air conditioner with multifunction. For the functions which the model doesn't have, if press the corresponding button on the remote controller, the unit will keep the original running status.
- After putting through the power, the air conditioner will give out a sound. Operation indicator "ON" is ON. After that, you can operate the air conditioner by using remote controller.
- Under on status, pressing the button on the remote controller, the signal icon "📶" on the display of remote controller will blink once and the air conditioner will give out a "di" sound, which means the signal has been sent to the air conditioner.
- As for the models with functions of WiFi or wired controller, the indoor unit must have been controlled by standard remote controller under auto mode first, and then the function of adjustable temperature under auto mode can be realized by APP or the wired controller.
- This remote controller can adjust the temperature under auto mode. When matching with the unit which is without the function of adjustable temperature under auto mode, the set temperature under auto mode may be invalid, or the displayed set temperature on the unit is not same as that on the remote controller under auto mode.

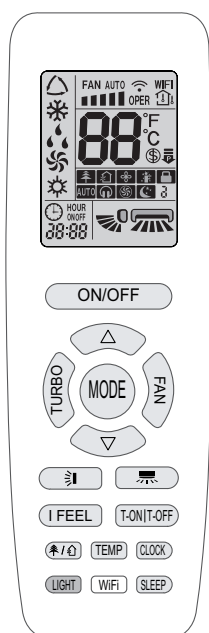

ON/OFF

Press this button to turn on the unit. Press this button again to turn off the unit.

MODE

Press this button to select your required operation mode.

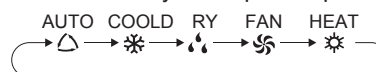

- When selecting auto mode, air conditioner will operate automatically according to ex-factory setting. Press "FAN" button can adjust fan speed. Press "🌀" / "🌀" button can adjust fan blowing angle.
- After selecting cool mode, air conditioner will operate under cool mode. Press "△" or "▽" button to adjust set temperature. Press "FAN" button to adjust fan speed. Press "🌀" / "🌀" button to adjust fan blowing angle.
- When selecting dry mode, the air conditioner operates at low speed under dry mode. Under dry mode, fan speed can't be adjusted. Press "🌀" / "🌀" button to adjust fan blowing angle.
- When selecting fan mode, the air conditioner will only blow fan, no cooling and no heating. All indicators are OFF. Press "FAN" button to adjust fan speed. Press "🌀" / "🌀" button to adjust fan blowing angle.
- When selecting heating mode, the air conditioner operates under heat mode. Press "△" or "▽" button to adjust set temperature. Press "FAN" button to adjust fan speed. Press "🌀" / "🌀" button to adjust fan blowing angle. (Cooling only unit won't receive heating mode signal. If setting heat mode with remote controller, press ON/OFF button can't start up the unit).

NOTE:

- For preventing cold air, after starting up heating mode, indoor unit will delay 1~5 minutes to blow air (actual delay time is depend on indoor ambient temperature).

Introduction for icons on display screen

	I feel	
	Set fan speed	
	Turbo mode	
	Send signal	
Operation mode		Auto mode
		Cool mode
		Dry mode
		Fan mode
		Heat mode
	Sleep mode	
	8°C heating function	
	Power limiting operation	
	Health mode	
	Scavenging function	
	X-FAN function	
Temp. display type		Set temp.
		Indoor ambient temp.
		Outdoor ambient temp.
	Clock	
	Set temperature	
	WiFi function	
	Set time	
	TIMER ON / TIMER OFF	
	Left & right swing	
	Up & down swing	
	Child lock	
	Quiet	

6. Function and Control

- Set temperature range from remote controller: 16~30°C (61-86°C).
- Under auto mode, temperature can be displayed; Under auto mode, set temperature can be adjusted.
- This mode indicator is not available for some models.



This button is used for setting Fan Speed in the sequence that goes from AUTO, , , , , to , then back to Auto.

NOTE:

- Under AUTO speed, air conditioner will select proper fan speed automatically according to factory default setting.
- It's low fan speed under dry mode.
- X-FAN function: Holding fan speed button for 2s in cool or dry mode, the icon " " is displayed and the indoor fan will continue operation for a few minutes in order to dry the indoor unit even though you have turned off the unit. After energization, X-FAN OFF is defaulted. X-FAN is not available in auto, fan or heat mode.

This function indicates that moisture on evaporator of indoor unit will be blown after the unit is stopped to avoid mould.

- Having set X-FAN function on: After turning off the unit by pressing ON/OFF button, indoor fan will continue running for a few minutes at low speed. In this period, hold fan speed button for 2s to stop indoor fan directly.

Having set X-FAN function off: After turning off the unit by pressing ON/OFF button, the complete unit will be off directly.



Under COOL or HEAT mode, press this button to turn to quick COOL or quick HEAT mode. " " icon is displayed on remote controller. Press this button again to exit turbo function and " " icon will disappear. If start this function, the unit will run at super-high fan speed to cool or heat quickly so that the ambient temp. approaches the preset temp. as soon as possible.



- Press "Δ" or "▽" button once increase or decrease set temperature 1°C (°F). Holding "Δ" or "▽" button, 2s later, set temperature on remote controller will change quickly. On releasing button after setting is finished, temperature indicator on indoor unit will change accordingly.
- When setting T-ON, T-OFF or CLOCK, press "Δ" or "▽" button to adjust time. (Refer to CLOCK, TON, T-OFF buttons)



Press this button can select left & right swing angle. Fan blow angle can be selected circularly as below:

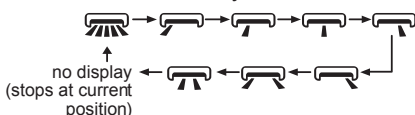

NOTE:

- Press this button continuously more than 2s, the main unit will swing back and forth from left to right, and then loosen the button, the unit will stop swinging and present position of guide louver will be kept immediately.
- Under left and right swing mode, when the status is switched from off to , if press this button again 2s later, status will switch to off status directly; if press this button again within 2s, the change of swing status will also depend on the circulation sequence stated above.
- The function is only available for some models.



Press this button can select up & down swing angle. Fan blow angle can be selected circularly as below:

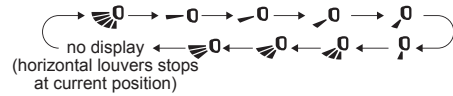

- When selecting " ", air conditioner is blowing fan automatically. Horizontal louver will automatically swing up & down at maximum angle.
- When selecting " , , , , ", air conditioner is blowing fan at fixed position. Horizontal louver will stop at the fixed position.
- When selecting " , , ", air conditioner is blowing fan at fixed angle. Horizontal louver will send air at the fixed angle.
- Hold " " button above 2s to set your required swing angle. When reaching your required angle, release the button.

NOTE:

- " , , " may not be available. When air conditioner receives this signal, the air conditioner will blow fan automatically.
- Press this button continuously for more than 2s, the main unit will swing back and forth from up to down, and then loosen the button, the unit present position of guide louver will be kept immediately.
- Under up and down swing mode, when the status is switched from off to , if press this button again 2s later, status will switch to off status directly; if press this button again within 2s, the change of swing status will also depend on the circulation sequence stated above.



- T-ON button
"T-ON" button can set the time for timer on. After pressing this button, " " icon disappears and the word "ON" on remote controller blinks. Press "Δ" or "▽" button to adjust T-ON setting. After each pressing "Δ" or "▽" button, T-ON setting will increase or decrease 1min. Hold "Δ" or "▽" button, 2s later, the time will change quickly until reaching your required time. Press "T-ON" to confirm it. The word "ON" will stop

6. Function and Control

blinking. "☉" icon resumes displaying. Cancel T-ON: Under the condition that T-ON is started up, press "T-ON" button to cancel it.

- T-OFF button

"T-OFF" button can set the time for timer off. After pressing this button, "☉" icon disappears and the word "OFF" on remote controller blinks. Press "△" or "▽" button to adjust T-OFF setting. After each pressing "△" or "▽" button, T-OFF setting will increase or decrease 1min. Hold "△" or "▽" button, 2s later, the time will change quickly until reaching your required time. Press "T-OFF" word "OFF" will stop blinking.

"☉" icon resumes displaying. Cancel T-OFF. Under the condition that T-OFF is started up, press "T-OFF" button to cancel it.

NOTE:

- Under on and off status, you can set T-OFF or T-ON simultaneously.
- Before setting T-ON or T-OFF, please adjust the clock time.
- After starting up T-ON or T-OFF, set the constant circulating valid.
- After that, air conditioner will be turned on or turned off according to setting time. ON/OFF button has no effect on setting. If you don't need this function, please use remote controller to cancel it.

I FEEL

Press this button to start I FEEL function and "🌡️" will be displayed on the remote controller. After this function is set, the remote controller will send the detected ambient temperature to the controller and the unit will automatically adjust the indoor temperature according to the detected temperature. Press this button again to cancel I FEEL function and "🌡️" will disappear.

- Please put the remote controller near user when this function is set. Do not put the remote controller near the object of high temperature or low temperature in order to avoid detecting inaccurate ambient temperature.

When I FEEL function is turned on, the remote controller should be put within the area where indoor unit can receive the signal sent by the remote controller.

CLOCK

Press this button to set clock time. "☉" icon on remote controller will blink. Press "△" or "▽" button within 5s to set clock time. Each pressing of "△" or "▽" button, clock time will increase or decrease 1 minute. If hold "△" or "▽" button, 2s later, time will change quickly. Release this button when reaching your required time. Press "CLOCK" button to confirm the time. "☉" icon stops blinking.

NOTE:

- Clock time adopts 24-hour mode.

- The interval between two operations can't exceed 5s. Otherwise, remote controller will quit setting status. Operation for TIMER ON/TIMER OFF is the same.

SLEEP

- Press this button, can select Sleep 1 (☾ 1), Sleep 2 (☾ 2), Sleep 3 (☾ 3) and cancel the Sleep, circulate between these, after electrified, Sleep Cancel is defaulted.

- Sleep 1 is Sleep mode 1, in Cool modes; sleep status after run for one hour, the main unit setting temperature will increase 1, two hours, setting temperature increased 2°C, then the unit will run at this setting temperature; In Heat mode: sleep status after run for one hour, the setting temperature will decrease 1, two hours, setting temperature will decrease 2, then the unit will run at this setting temperature.

- Sleep 2 is sleep mode 2, that is air conditioner will run according to the presetting a group of sleep temperature curve.

- Sleep 3-the sleep curve setting under Sleep mode by DIY;
(1) Under Sleep 3 mode, press "TURBO" button for a long time, remote controller enters into user individuation sleep setting status, at this time, the time of remote controller will display "1hour", the setting temperature "88" will display the corresponding temperature of last setting sleep curve and blink (The first entering will display according to the initial curve setting value of original factory);

- (2) Adjust "△" or "▽" button, could change the corresponding setting temperature, after adjusted, press "TURBO" button for confirmation;

- (3) At this time, 1hour will be automatically increased at the timer position on the remote control, (that are "2hours" or "3hours" or "8hours"), the place of setting temperature "88" will display the corresponding temperature of last setting sleep curve and blink;

- (4) Repeat the above step (2)~(3) operation, until 8 hours temperature setting finished, sleep curve setting finished, at this time, the remote controller will resume the original timer display; temperature display will resume to original setting temperature.

- Sleep3- the sleep curve setting under Sleep mode by DIY could be inquired:

The user could accord to sleep curve setting method to inquire the presetting sleep curve, enter into user individuation sleep setting status, but do not change the temperature, press "TURBO" button directly for confirmation. Note: In the above presetting or enquiry procedure, if continuously within 10s, there is no button pressed, the sleep curve setting within 10s, there is no button pressed, the sleep curve setting status will be automatically quit and resume to display the original displaying. In the presetting or enquiry procedure, press "ON/OFF" button, "MODE" button, "SLEEP" button, the sleep curve setting or enquiry status will quit similarly.

6. Function and Control

WiFi

Press " WiFi " button to turn on WiFi function, " WiFi " icon will be displayed on the remote controller; Hold " WiFi " button for 5s to turn off WiFi function and " WiFi " icon will disappear. Under off status, press "MODE" and " WiFi " buttons simultaneously for 1s, WiFi module will restore factory settings.

NOTE:

- The function is only available for some models.

🏠/🏠

Press this button to achieve the on and off of health and scavenging functions in operation station. Press this button for the first time to start scavenging function; LCD displays " 🏠 ". Press the button for the second time to start health and scavenging functions simultaneously; LCD displays " 🏠 " and " 🏠 ". Press this button for the third time to quit health and scavenging functions simultaneously. Press the button for the fourth time to start health function; LCD display " 🏠 ". Press this button again to repeat the operation above.

- This function is applicable to partial of models .

LIGHT

Press this button to turn off display light on indoor unit. " 🌞 " icon on remote controller disappears.

Press this button again to turn on display light. " 🌞 " icon is displayed.

TEMP

Press this button, you can see indoor set temperature, indoor ambient temperature on indoor unit' s display. The setting on remote controller is selected circularly as below:



Function introduction for combination buttons

Energy-saving function

Under cooling mode, press "TEMP" and "CLOCK" buttons simultaneously to start up or turn off energy-saving function. When energy-saving function is started up, "SE" will be shown on remote controller, and air conditioner will adjust the set temperature automatically according to ex-factory setting to reach to the best energy-saving effect.

Press "TEMP" and "CLOCK" buttons simultaneously again to exit energy-saving function.

NOTE:

- Under energy-saving function, fan speed is defaulted at auto speed and it can't be adjusted.
- Under energy-saving function, set temperature can't be adjusted. Press "TURBO" button and the remote controller won't send signal.

- Sleep function and energy-saving function can't operate at the same time. If energy-saving function has been set under cool mode, press SLEEP button will cancel energy-saving function. If sleep function has been set under cool mode, start up the energy-saving function will cancel sleep function.

8°C heating function

Under heat mode, press "TEMP" and "CLOCK" buttons simultaneously to start up or turn off 8°C heating function. When this function is started up, " 8°C " and " 8°C " will be shown on remote controller, and the air conditioner keep the heating status at 8°C . Press "TEMP" and "CLOCK" buttons simultaneously again to exit 8°C heating function.

NOTE:

- Under 8°C heating function, fan speed is defaulted at auto speed and it can't be adjusted.
- Under 8°C heating function, set temperature can't be adjusted. Press "TURBO" button and the remote controller won't send signal.
- Sleep function and 8°C heating function can't operate at the same time. If 8°C heating function has been set under heat mode, press SLEEP button will cancel 8°C heating function. If sleep function has been set under heat mode, start up the 8°C heating function will cancel sleep function.
- Under °F temperature display, the remote controller will display 46 °F heating.

Child lock function

Press "△" or "▽" simultaneously to turn on or turn off child lock function. When child lock function is on, " 🚫 " icon is displayed on remote controller. If you operate the remote controller, the " 🚫 " icon will blink three times without sending signal to the unit.

Temperature display switchover function

Under OFF status, press "▽" and "MODE" buttons simultaneously to switch temperature display between °C and °F .

6. Function and Control

Replacement of batteries in remote controller

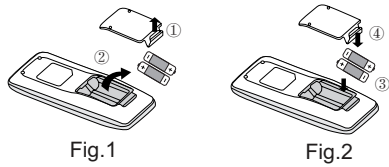

1. Lift the cover along the direction of arrow (as shown in Fig 1 ①).
2. Take out the original batteries (as shown in Fig 1 ②).
3. Place two 7# (AAA 1.5V) dry batteries, and make sure the position of “+” polar and “-” polar is correct (as shown in Fig 2 ③).
4. Reinstall the cover (as shown in Fig 2 ④).

Notice:

- During operation, point the remote control signal sender at the receiving window on indoor unit.
- The distance between signal sender and receiving window should be no more than 8m, and there should be no obstacles between them.
- Signal may be interfered easily in the room where there is fluorescent lamp or wireless telephone; remote controller should be close to indoor unit during operation.
- Replace new batteries of the same model when replacement is required.
- When you don't use remote controller for a long time, please take out the batteries.
- If the display on remote controller is fuzzy or there's no display, please replace batteries.

6. Function and Control

6.2 Brief Description of Models and Functions

● Indoor Unit

1. Basic function of system

(1) Cooling mode

(1) Under this mode, fan and swing operates at setting status. Temperature setting range is 16~30°C.

(2) During malfunction of outdoor unit or the unit is stopped because of protection, indoor unit keeps original operation status.

(2)Drying mode

(1) Under this mode, fan operates at low speed and swing operates at setting status. Temperature setting range is 16~30°C.

(2) During malfunction of outdoor unit or the unit is stopped because of protection, indoor unit keeps original operation status.

(3) Protection status is same as that under cooling mode.

(4) Sleep function is not available for drying mode.

(3)Heating mode

(1) Under this mode, Temperature setting range is 16~30°C.

(2) Working condition and process for heating mode:

When turn on the unit under heating mode, indoor unit enters into cold air prevention status. When the unit is stopped or at OFF status, and indoor unit has been started up just now, the unit enters into residual heat-blowing status.

(4)Working method for AUTO mode:

1.Working condition and process for AUTO mode:

a.Under AUTO mode, standard heating $T_{\text{preset}}=20^{\circ}\text{C}$ and standard cooling $T_{\text{preset}}=25^{\circ}\text{C}$. The unit will switch mode automatically according to ambient temperature.

2.Protection function

a. During cooling operation, protection function is same as that under cooling mode.

b. During heating operation, protection function is same as that under heating mode.

3. Display: Set temperature is the set value under each condition. Ambient temperature is ($T_{\text{amb.}}-T_{\text{compensation}}$) for heat pump unit and $T_{\text{amb.}}$ for cooling only unit.

4. If theres I feel function, $T_{\text{compensation}}$ is 0. Others are same as above.

(5)Fan mode

Under this mode, indoor fan operates at set fan speed. Compressor, outdoor fan, 4-way valve and electric heating tube stop operation. Indoor fan can select to operate at high, medium, low or auto fan speed. Temperature setting range is 16~30°C.

2. Other control

(1) Buzzer

Upon energization or availably operating the unit or remote controller, the buzzer will give out a beep.

(2) Auto button

If press this auto button when turning off the unit, the complete unit will operate at auto mode. Indoor fan operates at auto fan

speed and swing function is turned on. Press this auto button at ON status to turn off the unit.

(3) Auto fan

Heating mode: During auto heating mode or normal heating ode, auto fan speed will adjust the fan speed automatically according to ambient temperature and set temperature.

(4) Sleep

After setting sleep function for a period of time, system will adjust set temperature automatically.

(5) Timer function:

General timer and clock timer functions are compatible by equipping remote controller with different functions.

(6) Memory function

memorize compensation temperature, off-peak energization value.

Memory content: mode, up&down swing, light, set temperature, set fan speed, general timer (clock timer Can't be memorized).

After power recovery, the unit will be turned on automatically according to memory content.

(7) Health function

During operation of indoor fan, set health function by remote controller. Turn off the unit will also turn off health function.

Turn on the unit by pressing auto button, and the health is defaulted ON.(Health function is not available for this unit)

(8)I feel control mode

After controller received I feel control signal and ambient temperature sent by remote controller, controller will work according to the ambient temperature sent by remote controller.

(9)Compulsory defrosting function

(1) Start up compulsory defrosting function

Under ON status, set heating mode with remote controller and adjust the temperature to 16°C.Press “ Δ , ∇ , Δ , ∇ , Δ , ∇ ” button successively within 5s and the complete unit will enter into compulsory defrosting status. Meanwhile, heating indicator on indoor unit will ON 10s and OFF 0.5s successively. (Note: If complete unit has malfunction or stops operation due to protection, compulsory defrosting function can be started up after malfunction or protection is resumed.

(2) Exit compulsory defrosting mode

After compulsory defrosting is started up, the complete unit will exit defrosting operation according to the actual defrosting result, and the complete unit will resume normal heating operation.

(10)Refrigerant recovery function:

(1) Enter refrigerant recycling function

Within 5min after energizing (unit ON or OFF status is ok), continuously press LIGHT button for 3 times within 3s to enter refrigerant recycling mode; Fo is displayed and refrigerant recycling function is started. At this moment, the maintenance people closes liquid valve.

After 5min, stick the thimble of maintenance valve with a tool. If there is no refrigerant spraying out, close the gas valve immediately and then turn off the unit to remove the connection

6. Function and Control

pipe.

(2) Exit refrigerant recycling function

After entering refrigerant recycling mode, when receive any remote control signal or enter refrigerant recycling mode for 25min, the unit will exit refrigerant recycling mode automatically. If the unit is in standby mode before refrigerant recycling, it will be still in standby mode after finishing refrigerant recycling; if the unit is in ON status before refrigerant recycling, it will still run in original operation mode.

(11) Ambient temperature display control mode

1. When user set the remote controller to display set temperature (corresponding remote control code: 01), current set temperature will be displayed.

2. Only when remote control signal is switched to indoor ambient temperature display status (corresponding remote control code: 10) from other display status (corresponding remote control code: 00, 01, 11), controller will display indoor ambient temperature for 3s and then turn back to display set temperature.

Under this mode, indoor fan operates at set fan speed. Compressor, outdoor fan, 4-way valve and electric heating tube stop operation. Indoor fan can select to operate at high, medium, low or auto fan speed. Temperature setting range is 16~30°C.

(12) Off-peak energization function:

Adjust compressors minimum stop time. The original minimum stop time is 180s and then we change to:

The time interval between two start-ups of compressor Can't be less than $180+T_s(0 \leq T \leq 15)$. T is the variable of controller. That's to say the minimum stop time of compressor is 180s~195s. Read-in T into memory chip when refurbish the memory chip each time. After power recovery, compressor can only be started up after $180+T$ s at least.

(13) SE control mode

The unit operates at SE status.

(14) X-fan mode

When X-fan function is turned on, after turn off the unit, indoor fan will still operate at low speed for 2min and then the complete unit will be turned off. When x-fan function is turned off, after turn off the unit, the complete unit will be turned off directly.

(15) 8°C heating function

Under heating mode, you can set 8°C heating function by remote controller. The system will operate at 8°C set temperature.

(16) Turbo function

Turbo function can be set under cooling and heating modes. Press Fan Speed button to cancel turbo setting. Turbo function is not available under auto, drying and fan modes.

(17) Instructions to the Error Indicating Lamps on the Panel of the Cassette Type Unit.

12~18K:

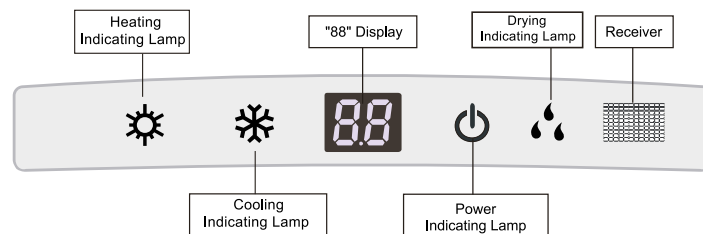

24K:

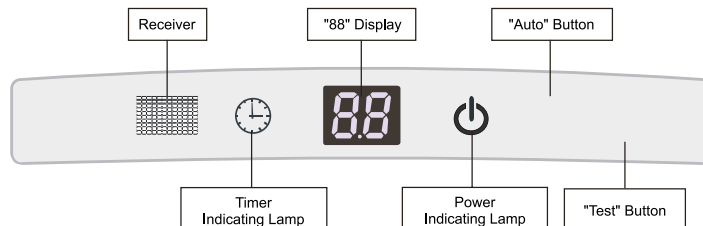

• Heating Indicating Lamp:

When this indicator is on, it indicates the heating mode is turned on.

• Cooling Indicating Lamp:

When this indicator is on, it indicates the cooling mode is turned on.

• Drying Indicating Lamp

When this indicator is on, it indicates the dry mode is turned on.

• Power and ON/OFF Indicating Lamp:

It goes red when the unit is powered on while it goes white when the unit is started.

• Timer Indicating Lamp:

Timer indicator on indoor unit will be on when timer ON is set under off status and timer OFF is set under on status.

• "88" Display:

When there is no error, the dual-8 nixie tube display the set temperature. After receiving the command of displaying indoor ambient temperature from the remote controller, the dual-8 nixie tube displays indoor temperature for 3s and then resume to display the set temperature. If there is error, error code will be displayed. If there's multiple error, error codes will be displayed in turn.

"Auto" button It's used for turning on or turning off the unit. When use this button to turn in the unit, the unit is under auto mode.

"Test" button It's only used for the test units. This button is only valid within 3mins after the unit is energized.

NOTE:

(1) If the light of indoor unit is turned off, when operating the remote controller to send command, the display will be on for 3s and then off.

(2) When the wired controller is connected, the indoor unit display is invalid and the unit won't receive the remote control command.

7. Notes for Installation and Maintenance

Safety Precautions: Important!

Please read the safety precautions carefully before installation and maintenance.

The following contents are very important for installation and maintenance.

Please follow the instructions below.

- The installation or maintenance must accord with the instructions.
- Comply with all national electrical codes and local electrical codes.
- Pay attention to the warnings and cautions in this manual.
- All installation and maintenance shall be performed by distributor or qualified person.
- All electric work must be performed by a licensed technician according to local regulations and the instructions given in this manual.
- Be caution during installation and maintenance. Prohibit incorrect operation to prevent electric shock, casualty and other accidents.



WARNINGS

Electrical Safety Precautions:

1. Cut off the power supply of air conditioner before checking and maintenance.
2. The air condition must apply specialized circuit and prohibit share the same circuit with other appliances.
3. The air conditioner should be installed in suitable location and ensure the power plug is touchable.
4. Make sure each wiring terminal is connected firmly during installation and maintenance.
5. Have the unit adequately grounded. The grounding wire Can't be used for other purposes.
6. Must apply protective accessories such as protective boards, cable-cross loop and wire clip.
7. The live wire, neutral wire and grounding wire of power supply must be corresponding to the live wire, neutral wire and grounding wire of the air conditioner.
8. The power cord and power connection wires Can't be pressed by hard objects.
9. If power cord or connection wire is broken, it must be replaced by a qualified person.
10. If the power cord or connection wire is not long enough, please get the specialized power cord or connection wire from the manufacture or distributor. Prohibit prolong the wire by yourself.

11. For the air conditioner without plug, an air switch must be installed in the circuit. The air switch should be all-pole parting and the contact parting distance should be more than 3mm.

12. Make sure all wires and pipes are connected properly and the valves are opened before energizing.

13. Check if there is electric leakage on the unit body. If yes, please eliminate the electric leakage.

14. Replace the fuse with a new one of the same specification if it is burnt down; dont replace it with a cooper wire or conducting wire.

15. If the unit is to be installed in a humid place, the circuit breaker must be installed.

Installation Safety Precautions:

1. Select the installation location according to the requirement of this manual.(See the requirements in installation part)
2. Handle unit transportation with care; the unit should not be carried by only one person if it is more than 20kg.
3. When installing the indoor unit and outdoor unit, a sufficient fixing bolt must be installed; make sure the installation support is firm.
4. Ware safety belt if the height of working is above 2m.
5. Use equipped components or appointed components during installation.
6. Make sure no foreign objects are left in the unit after finishing installation.

Refrigerant Safety Precautions:

1. When refrigerant leaks or requires discharge during installation, maintenance, or disassembly, it should be handled by certified professionals or otherwise in compliance with local laws and regulations.
- 2.Avoid contact between refrigerant and fire as it generates poisonous gas; Prohibit prolong the connection pipe by welding.
3. Apply specified refrigerant only. Never have it mixed with any other refrigerant. Never have air remain in the refrigerant line as it may lead to rupture or other hazards.
4. Make sure no refrigerant gas is leaking out when installation is completed.
5. If there is refrigerant leakage, please take sufficient measure to minimize the density of refrigerant.
6. Never touch the refrigerant piping or compressor without wearing glove to avoid scald or frostbite.

Improper installation may lead to fire hazard, explosion, electric shock or injury.

7. Notes for Installation and Maintenance

Safety Precautions for Installing and Relocating the Unit:

To ensure safety, please be mindful of the following precautions.

WARNINGS

1. When installing or relocating the unit, be sure to keep the refrigerant circuit free from air or substances other than the specified refrigerant.

Any presence of air or other foreign substance in the refrigerant circuit will cause system pressure rise or compressor rupture, resulting in injury.

2. When installing or moving this unit, do not charge the refrigerant which is not comply with that on the nameplate or unqualified refrigerant.

Otherwise, it may cause abnormal operation, wrong action, mechanical malfunction or even series safety accident.

3. When refrigerant needs to be recovered during relocating or repairing the unit, be sure that the unit is running in cooling mode. Then, fully close the valve at high pressure side (liquid valve). About 30-40 seconds later, fully close the valve at low pressure side (gas valve), immediately stop the unit and disconnect power. Please note that the time for refrigerant recovery should not exceed 1 minute.

If refrigerant recovery takes too much time, air may be sucked in and cause pressure rise or compressor rupture, resulting in injury.

4. During refrigerant recovery, make sure that liquid valve and gas valve are fully closed and power is disconnected before detaching the connection pipe.

If compressor starts running when stop valve is open and connection pipe is not yet connected, air will be sucked in and cause pressure rise or compressor rupture, resulting in injury.

5. When installing the unit, make sure that connection pipe is securely connected before the compressor starts running.

If compressor starts running when stop valve is open and connection pipe is not yet connected, air will be sucked in and cause pressure rise or compressor rupture, resulting in injury.

6. Prohibit installing the unit at the place where there may be leaked corrosive gas or flammable gas.

If there leaked gas around the unit, it may cause explosion and other accidents.

7. Do not use extension cords for electrical connections. If the electric wire is not long enough, please contact a local service center authorized and ask for a proper electric wire.

Poor connections may lead to electric shock or fire.

8. Use the specified types of wires for electrical connections between the indoor and outdoor units. Firmly clamp the wires so that their terminals receive no external stresses.

Electric wires with insufficient capacity, wrong wire connections and insecure wire terminals may cause electric shock or fire.

7. Notes for Installation and Maintenance

Safety Precautions for Refrigerant

- To realize the function of the air conditioner unit, a special refrigerant circulates in the system. The used refrigerant is the fluoride R32, which is specially cleaned. The refrigerant is flammable and odorless. Furthermore, it can lead to explosion under certain conditions. But the flammability of the refrigerant is very low. It can be ignited only by fire.
- Compared to common refrigerants, R32 is a nonpolluting refrigerant with no harm to the ozone layer. The influence upon the greenhouse effect is also lower. R32 has got very good thermodynamic features which lead to a really high energy efficiency. The units therefore need a less filling.

WARNING:

- Do not use means to accelerate the defrosting process or to clean, other than those recommended by the manufacturer. Should repair be necessary, contact your nearest authorized Service Centre. Any repairs carried out by unqualified personnel may be dangerous. The appliance shall be stored in a room without continuously operating ignition sources. (for example: open flames, an operating gas appliance or an operating electric heater.)
- Do not pierce or burn.
- Appliance shall be installed, operated and stored in a room with a floor area larger than X m².
- Appliance filled with flammable gas R32. For repairs, strictly follow manufacturer's instructions only. Be aware that refrigerants do not contain odor.
- Read specialist's manual.

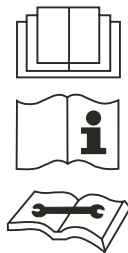

Safety Operation of Flammable Refrigerant

Qualification requirement for installation and maintenance man

- All the workmen who are engaged in the refrigeration system should bear the valid certification awarded by the authoritative organization and the qualification for dealing with the refrigeration system recognized by this industry. If it needs other technician to maintain and repair the appliance, they should be supervised by the person who bears the qualification for using the flammable refrigerant.
- It can only be repaired by the method suggested by the equipment's manufacturer.

Installation notes

- The air conditioner is not allowed to use in a room that has running fire (such as fire source, working coal gas ware, operating heater).
 - It is not allowed to drill hole or burn the connection pipe.
 - The air conditioner must be installed in a room that is larger than the minimum room area.
- The minimum room area is shown on the nameplate or following table a.
- Leak test is a must after installation.

table a - Minimum room area (m²)

Charge amount (kg)	floor location	window mounted	wall mounted	ceiling mounted
≤1.2	/	/	/	/
1.3	14.5	5.2	1.6	1.1
1.4	16.8	6.1	1.9	1.3
1.5	19.3	7	2.1	1.4
1.6	22	7.9	2.4	1.6
1.7	24.8	8.9	2.8	1.8
1.8	27.8	10	3.1	2.1
1.9	31	11.2	3.4	2.3
2	34.3	12.4	3.8	2.6
2.1	37.8	13.6	4.2	2.8
2.2	41.5	15	4.6	3.1
2.3	45.4	16.3	5	3.4
2.4	49.4	17.8	5.5	3.7
2.5	53.6	19.3	6	4

Maintenance notes

- Check whether the maintenance area or the room area meet the requirement of the nameplate.
 - Its only allowed to be operated in the rooms that meet the requirement of the nameplate.
- Check whether the maintenance area is well-ventilated.
 - The continuous ventilation status should be kept during the operation process.
- Check whether there is fire source or potential fire source in the maintenance area.
 - The naked flame is prohibited in the maintenance area; and the “no smoking” warning board should be hanged.
- Check whether the appliance mark is in good condition.
 - Replace the vague or damaged warning mark.

Welding

- If you should cut or weld the refrigerant system pipes in the process of maintaining, please follow the steps as below:
 - a. Shut down the unit and cut power supply
 - b. Eliminate the refrigerant
 - c. Vacuuming
 - d. Clean it with N₂ gas
 - e. Cutting or welding

7. Notes for Installation and Maintenance

f. Carry back to the service spot for welding

- Make sure that there isn't any naked flame near the outlet of the vacuum pump and it's well-ventilated.
- The refrigerant should be recycled into the specialized storage tank.

Filling the refrigerant

- Use the refrigerant filling appliances specialized for R32. Make sure that different kinds of refrigerant won't contaminate with each other.
- The refrigerant tank should be kept upright at the time of filling refrigerant.
- Stick the label on the system after filling is finished (or haven't finished).
- Don't overfilling.
- After filling is finished, please do the leakage detection before test running; another time of leak detection should be done when it's removed.

Safety instructions for transportation and storage

- Please use the flammable gas detector to check before unload and open the container.
- No fire source and smoking.
- According to the local rules and laws.

7. Notes for Installation and Maintenance

Main Tools for Installation and Maintenance



Level meter



Measuring tape



Screw driver



Impact drill



Drill head



Electric drill



Electroprobe



Universal meter



Torque wrench



Open-end wrench



Inner hexagon spanner



Electronic leakage detector



Vacuum pump



Pressure meter



Pipe pliers



Pipe pliers



Pipe cutter



Pipe expander



Pipe bender



Soldering appliance



Refrigerant container



Electronic scale

8. Installation

8.1 Outline of the Unit and Main Parts

Indoor

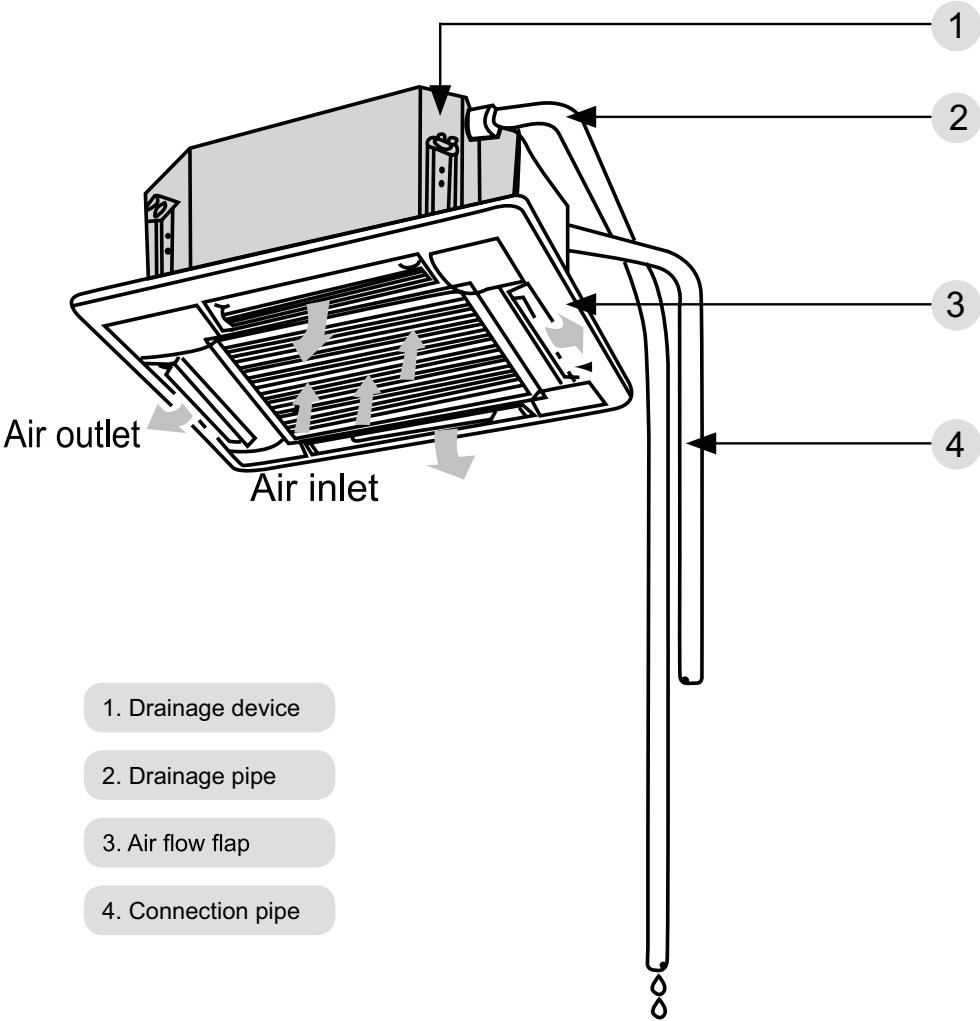

















8. Installation

8.2 Preparative for Installation

8.2.1 Standard Accessory Parts

The standard accessory parts listed below are furnished and should be used as required.

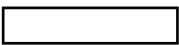
Table 1

Indoor Unit Accessories				
No.	Name	Appearance	Q'ty	Usage
1	Drain Hose		1	To connect with the hard PVC drain pipe
2	Nut with Washer		4	To fix the hook on the cabinet of the unit.
3	Washer		10	To be used together with the hanger bolt for installing the unit.
4	Installation Paperboard		1	Used for ceiling drilling
5	Gasket Mounting Board		4	Used to prevent gasket from falling off
6	Remote Controller +Battery		1+2	To control the indoor unit
7	Sealing Plaster		1	Used for holes through the wall
8	Fastener		6	To fasten the sponge
9	Insulation		1	To insulate the gas pipe
10	Insulation		1	To insulate the liquid pipe
11	Sponge		4	To insulate the drain pipe
12	Nut		1	To connect gas pipe
13	Nut		1	To connect liquid pipe
14	Enswathement		2	Used for winding the pipe connecting the indoor and outdoor units
15	Heat-Shrinkable Bushing		1	Connect the front panel to the main body
16	Bolt Assembly		4	Connect the panel and body (only 12K/18K)

8.2.2 Selection of the Installation Location

WARNING!

The unit must be installed where strong enough to withstand the weight of the unit and fixed securely, otherwise the unit would topple or fall off.

CAUTION!

- ① . Do not install where there is the danger of combustible gas leakage.
- ② . Do not install the unit near heat source of heat, steam, or flammable gas.
- ③ . Children under 10 years old must be supervised not to operate the unit.

Decide the installation location with the customer as follows:

8. Installation

8.3 Installation of Cassette Type

8.3.1. Before Installation

After receiving the machine, please check for any transport damage. If finding any surface or internal damage, please immediately report to the transport company or equipment company in writing.

After receiving the machine, please check the unit and accessories in reference to the packing list.

Ensure that the model is correct and the machine is in good condition. Please also check if the specification and quantity of accessory parts are correct.

Determine the correct handling route and methods, thus to avoid damaging the unit or causing possible hazard.

For the sake of protection and safety, it is suggested to move the unit with the packaging box. Even though it is not permitted to do like this under special occasions, do not remove the packaging box, thus to avoid loosening or falling during handling.

Confirm if the installing foundation is solid. When this unit is to be installed on the metal section of the building, make sure that the electrical insulation must comply with applicable standards.

Ensure that the place of installation is far from the area where the inflammable or explosive substances are stored, thus to avoid possible explosion or fire due to leakage.

8.3.2. Installation Site

Select an installation site where the following conditions are fulfilled and that meets your customer's approval.

(1) Obstruct should be put away from the intake or outlet vent of the indoor unit so that the airflow can be blown through all the room.

(2) Make sure that the installation meets the requirement of the schematic diagram of installation spaces.

(3) Select the place where can stand 4 times of the weight of the indoor unit and would not increase the operating noise and vibration.

(4) The horizontality of the installation place should be guaranteed.

(5) Select the place where is easy to drain out the condensate water, and connect with outdoor unit.

(6) Make sure that there are enough space for care and maintenance, and the height fall between the indoor unit and ground is above 1800mm.

(7) When installing the suspension bolt, check if the installation place can stand 4 times of the weight of the unit. If not, reinforce it before installation.

Note: There will be large amount of greasy dirt accumulated on the fan, heat exchanger and water pump located in the dining room and kitchen, which would reduce the capacity of the heater exchanger, lead to leakage and abnormal operation of the water pump.

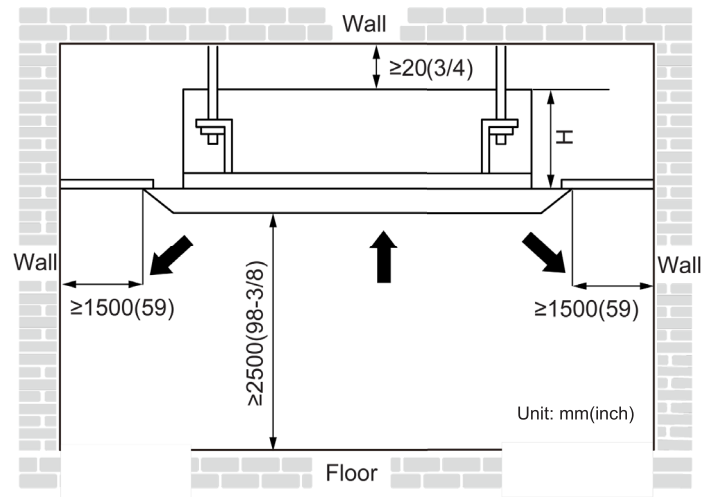

Fig.1

Table 2

Models	H(mm)
CHML-IC12RK2	295
CHML-IC18RK2	
CHML-IC24RK2	270

8.3.3. Connection Pipe Requirement



The maximum length of the connection pipe is listed in the table below. Do not place the units between which the distance exceeds the maximum length of the connection pipe.

Table 3

Item	Size of Fitting Pipe(Inch)		Max. Pipe Length (m)	Max. Height Difference between Indoor Unit and Outdoor Unit (m)	Drainage pipe(Outer Diameter × wall thickness) (mm)
	Liquid	Gas			
CHML-IC12RK2	1/4	3/8	30	15	Φ25x1.5
CHML-IC18RK2		1/2	35	20	
CHML-IC24RK2		5/8	50	25	

The connection pipe should be insulated with proper water-proof insulating material. The pipe wall thickness shall be 0.5-1.0mm and the pipe wall shall be able to withstand the pressure of 6.0 MPa. The longer the connecting pipe, the lower the cooling and heating effect performs.

8.3.4. Electrical Requirement

Electric Wire Size and Fuse Capacity.

Table 4

Indoor Units	Power Supply	Fuse Capacity	Min. Power Supply Cord
	V/Ph/Hz	A	mm ²
12~24k	220-240V~ 50Hz	5	4x0.75

8. Installation

Notes:

- (1). The fuse is located on the main board.
- (2). Install the disconnect device with a contact gap of at least 3mm in all poles nearby the units (Both indoor unit and outdoor unit). The appliance must be positioned so that the plug is accessible.
- (2). The specifications of the power cable listed in the table above are applied to the conduit-guarded multi-wire copper cable (like, YJV copper cable, consisting of PE insulated wires and a PVC cable jacket) used at 40°C and resistible to 90°C (see IEC 60364-5-52). If the working condition changes, they should be modified according to the related national standard.

8.3.5 Installing of the Unit

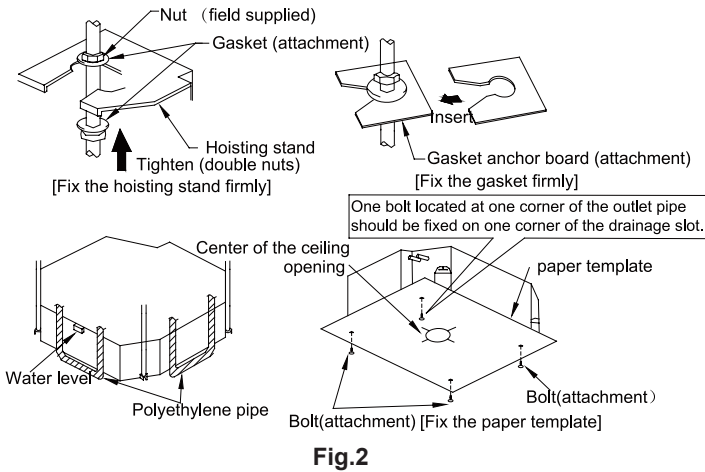

Fig.2

- (1). Install the hoisting stand on the hoisting screw by using nuts and gaskets at both the upper and lower sides of the hoisting stand. To prevent the gasket from breaking off, a gasket anchor board can be helpful.
- (2). Install the paper template on the unit, and fix the drain pipe at the outlet vent
- (3). Adjust the unit to the best position.
- (4). Check if the unit is installed horizontally at four directions. If not, the water pump and the float switch would function improperly and even lead to water leakage
- (5). Remove the gasket anchor board and tighten the nut remained.
- (6). Remove the paper template.

Note:

1. Drilling of ceiling opening and installation of air conditioner must be performed by professionals!
2. Please refer to the installation cardboard for the dimension of drilling hole of lifting screw of cassette unit.

8.3.6 Installing the Suspension Bolts

- (1) Using the installation template, drill holes for bolts (four holes). (Fig.3)
- (2) Install the bolts to the ceiling at a place strong enough to hang the unit. Mark the bolt positions from the installation template. With a concrete drill, drill for 12.7 mm (1/2") diameter holes. (Fig.4)
- (3) Insert the anchor bolts into the drilled holes, and drive the pins completely into the anchor bolts with a hammer. (Fig.5)

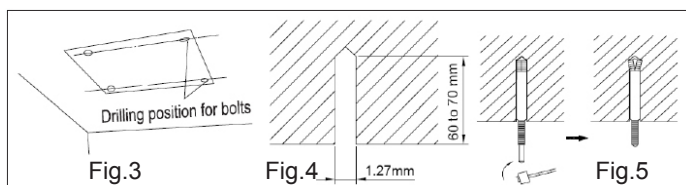

8.3.7. Leveling

The water level test must be done after installing the indoor unit to make the unit is horizontal, as shown below.

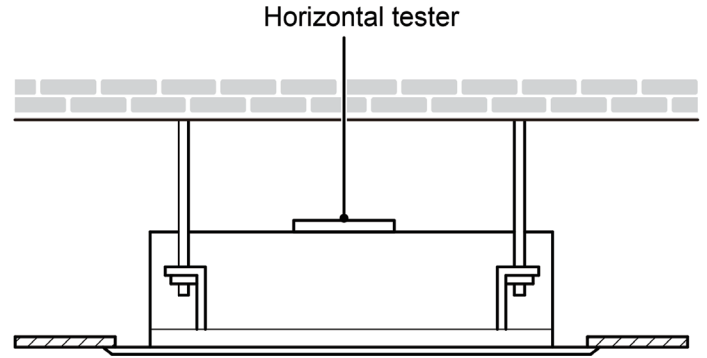

Fig.6

8.4 Installation of the Connection Pipe

8.4.1 Flare Processing .

- (1). Cut the connection pipe with the pipe cutter and remove the burrs.
- (2). Hold the pipe downward to prevent cuttings from entering the pipe.
- (3). Remove the flare nuts at the stop valve of the outdoor unit and inside the accessory bag of the indoor unit, then insert them to the connection pipe, after that, flare the connection pipe with a flaring tool.
- (4). Check with the flare part is spread evenly and there are no cracks (See Fig.7)

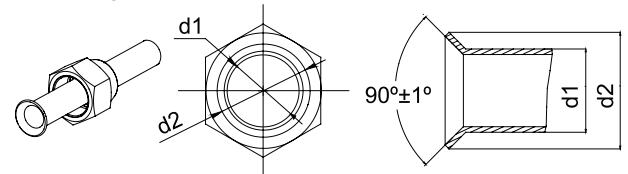

Fig.7

8.4.2 Bending Pipes

- (1). The pipes are shaped by your hands. Be careful not to collapse them.

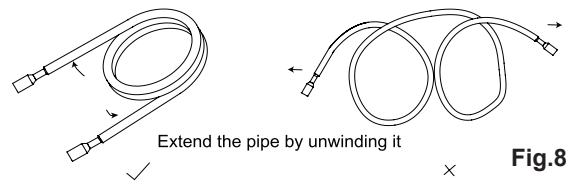

Fig.8

- (2). Do not bend the pipes in an angle more than 90°.

- (3). When pipes are repeatedly bent or stretched, the material will more. Do not bend or stretch the pipes more than three times.

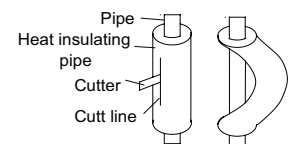

Fig.9

- (4). When bending the pipe, do not bend it as is. The pipe will be collapsed. In this case, cut the heat-insulating pipe with a sharp cutter as shown in Fig.9, and bend it after exposing the pipe. After bending the pipe as you want, be sure to put the heat-insulating pipe back on the pipe, and secure it with tape.

8. Installation

⚠ CAUTION!

- ① . To prevent breaking of the pipe, avoid sharp bends. Bend the pipe with a radius of curvature of 150mm or over.
- ② . If the pipe is bent repeatedly at the same place, it will break.

8.4.3 Connecting the Pipe at the Indoor Unit Side

Detach the caps and plugs from the pipes.

⚠ CAUTION!

- ① . Be sure to apply the pipe against the port on the indoor unit correctly. If the centering is improper, the flare nut cannot be tightened smoothly. If the flare nut is forced to turn, the threads will be damaged.
- ② . Do not remove the flare nut until the connection pipe is to be connected so as to prevent dust and impurities from coming into the pipe system.

When connecting the pipe to the unit or removing it from the unit, please do use both the spanner and the torque wrench.(Fig.10) When connecting, smear both inside and outside of the flare nut with refrigeration oil, screw it hand tight and then tighten it with the spanner.

Refer to Table to check if the wrench has been tightened properly (too tight would mangle the nut and lead to leakage). Examine the connection pipe to see if it leaks, then take the treatment of heat insulation, as shown in the Fig.10. Use the medium-sized sponge to insulate the coupler of the gas pipe.

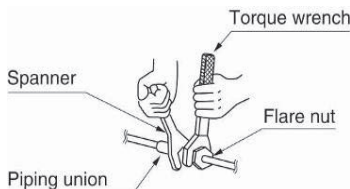
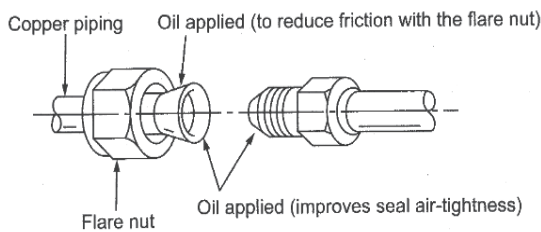
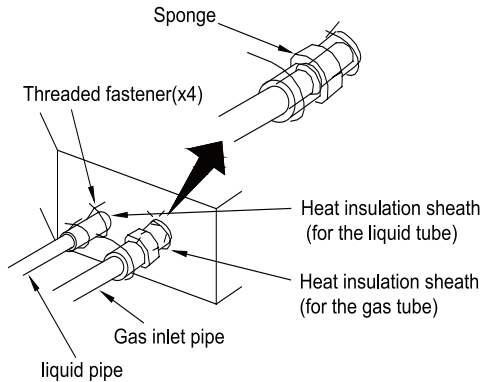

Fig.10

Table 5 Flare nut tightening torque

Pipe Diameter	Tightening Torque
1/4"(Inch)	15-30 (N·m)
3/8"(Inch)	35-40 (N·m)
5/8"(Inch)	60-65 (N·m)
1/2"(Inch)	45-50 (N·m)
3/4"(Inch)	70-75 (N·m)
7/8"(Inch)	80-85 (N·m)

⚠ CAUTION!

Be sure to connect the gas pipe after connecting the liquid pipe completely.

8.4.4 Connecting the Pipe at the Outdoor Side Unit

Tighten the flare nut of the connection pipe at the outdoor unit valve connector. The tightening method is the same as that as at the indoor side.

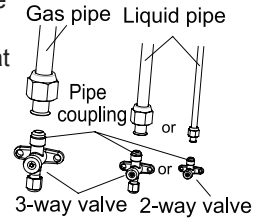

Fig.11

8.4.5 Checking the Pipe Connections for Gas Leaking

For both indoor and outdoor unit side, check the joints for gas leaking by the use of a gas leakage detector without fail when the pipes are connected.

8.4.6 Heat Insulation on the Pipe Joints (Indoor Side Only)

Stick coupler heat insulation (large and small) to the place where connecting pipes.

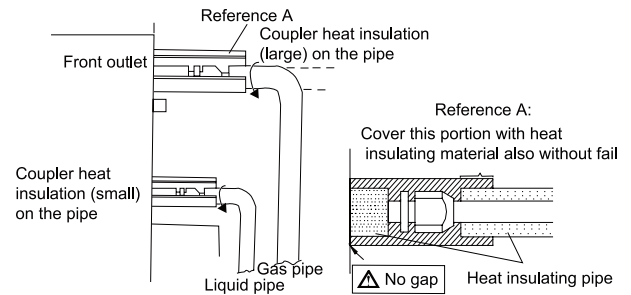

Fig.12

8.4.7 Liquid Pipe and Drain Pipe

If the outdoor unit is installed lower than the indoor unit (See Fig.13)

- (1). A drain pipe should be above ground and the end of the pipe does not dip into water. All pipes must be restrained to the wall by saddles.
- (2). Taping pipes must be done from bottom to top.(3). All pipes are bound together by tape and restrained to wall by saddles.

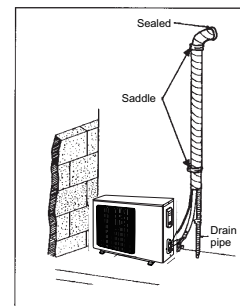

Fig.13

8. Installation

If the outdoor unit is installed higher than the indoor unit (See Fig.14)

- (1). Taping should be done from lower to the upper part.
- (2). All pipes are bound and taped together and also should be trapped to prevent water from returning to the room.
- (3). Restraint all pipes to the wall with saddles.

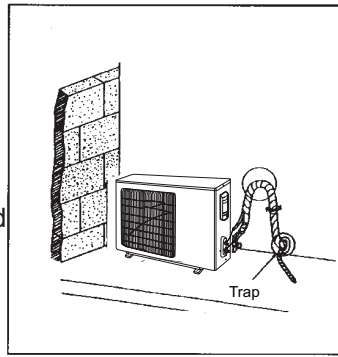
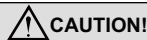

Fig.14

8.4.8 Vacuum and Gas Leakage Inspection



Do not purge the air with refrigerants but use a vacuum pump to vacuum the installation! There is no extra refrigerant in the outdoor unit for air purging!

8.4.8.9 Vacuum

- (1). Remove the caps of the liquid valve, gas valve and also the service port.
- (2). Connect the hose at the low pressure side of the manifold valve assembly to the service port of the unit's gas valve, and meanwhile the gas and liquid valves should be kept closed in case of refrigerant leak.
- (3). Connect the hose used for evacuation to the vacuum pump.
- (4). Open the switch at the lower pressure side of the manifold valve assembly and start the vacuum pump. Meanwhile, the switch at the high pressure side of the manifold valve assembly should be kept closed, otherwise evacuation would fail.
- (5). The evacuation duration depends on the unit's capacity, generally, 15 minutes for the 12k units, 20 minutes for the 18k units, 30 minutes for the 24 units. And verify if the pressure gauge at the low pressure side of the manifold valve assembly reads -1.0Mp (-75cmHg), if not, it indicates there is leak somewhere. Then, close the switch fully and then stop the vacuum pump.
- (6). Wait for some time to see if the system pressure can remain unchanged, 3 minutes for the units less than 18k, 5 minutes for the 18K~24k units. During this time, the reading of the pressure gauge at the low pressure side can not be larger than 0.005Mp (0.38cmHg).
- (7). Slightly open the liquid valve and let some refrigerant go to the connection pipe to balance the pressure inside and outside of the connection pipe, so that air will not come into the connection pipe when removing the hose. Note that the gas and liquid valve can be opened fully only after the manifold valve assembly is removed.
- (8). Place back the caps of the liquid valve, gas valve and also the service port.

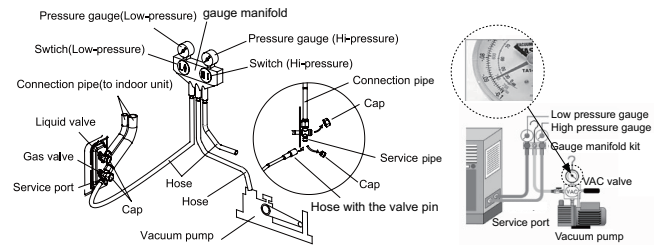

Fig.15

Note: For the large-sized unit, it has the service port for both the gas valve and the liquid valve. During evacuation, it is available to connect two hoses of the manifold valve assembly to two service ports to quicken the evacuating speed.

8.5 Installation of the Drain Hose

8.5.1 Installation of Drain Piping

- (1). Keep piping as short as possible and slope it downwards at a gradient of at least 1/100 so that air may not remain trapped inside the pipe.
- (2). Keep pipe size equal to or greater than that of the connecting pipe.
- (3). Install the drain piping as shown and take measures against condensation. Improperly rigged piping could lead to leaks and eventually wet furniture and belongings.

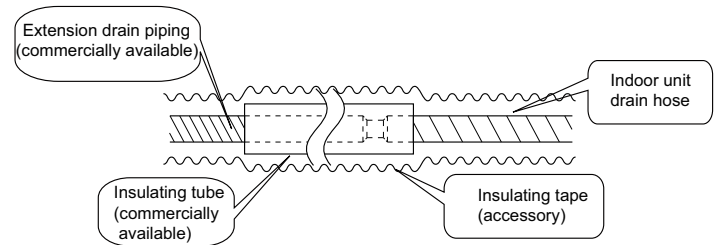
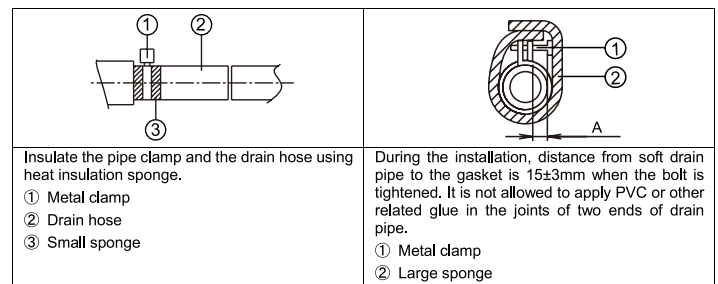

Fig.16

8.5.2 Installing the Drain Pipes

- (1). Insert the drain pipe to the drain outlet of the unit and then tighten the clamp securely with tape.
- (2). Connect the extension drain pipe to the drain pipe and then tighten the clamp with tape.



Insulate the pipe clamp and the drain hose using heat insulation sponge.

- ① Metal clamp
- ② Drain hose
- ③ Small sponge

During the installation, distance from soft drain pipe to the gasket is 15±3mm when the bolt is tightened. It is not allowed to apply PVC or other related glue in the joints of two ends of drain pipe.

- ① Metal clamp
- ② Large sponge

Indoor Unit	A
CHML-IC12RK2	≤12mm
CHML-IC18RK2	
CHML-IC24RK2	≤15mm

8. Installation

(3). When unifying multiple drain pipes, install the pipes as Fig.17. Select converging drain pipes whose gauge is suitable for the operating capacity of the unit.(take the cassette type unit for example)

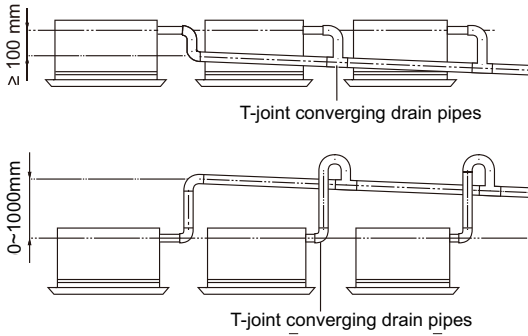

Fig.17

(4). When the drain hose cannot keep a sufficient gradient, it is necessary to fit a riser pipe(field supplied) to it.

(5). If the air flow if indoor unit is high, the might cause negative pressure and result in return suction of outdoor air. Therefore, U-type water trap shall be designed on the drainage side of each indoor unit.(Fig.18)

(6). Install one water trap for each unit.

(7). Installation of water trap shall consider easy cleaning in the future.

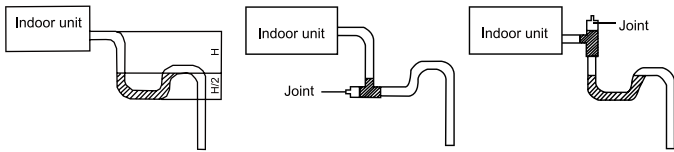

Fig.18

Fig.19

Fig.20

(8). Connection of drainage branch pipe to the standpipe or horizontal pipe of drainage main pipe

The horizontal pipe cannot be connected to the vertical pipe at a same height. It can be connected in a manner as shown below:

No.1: Attach the 3-way connection of the drainage pipe joint as shown in Fig.21.

No.2: Attach the drain elbow as shown in Fig.22.

No.3: Attach the horizontal pipe as shown in Fig.23

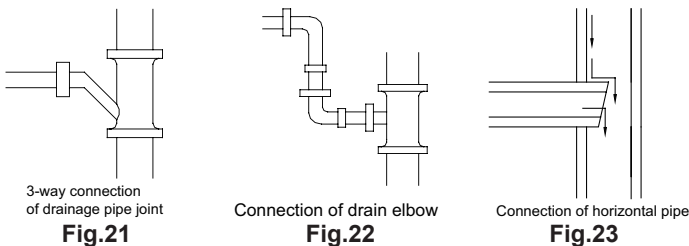

Fig.21

Fig.22

Fig.23

8.5.3 Precautions When Doing Riser Piping Work

(1). Make sure that heat insulation work is executed on the following 2 spots to prevent any possible water leakage due to dew condensation.

1). Connect the drain hose to the drain lift pipe, and insulate them.

2). Connect the drain hose to the drain outlet on the indoor unit, and tighten it with the clamp.

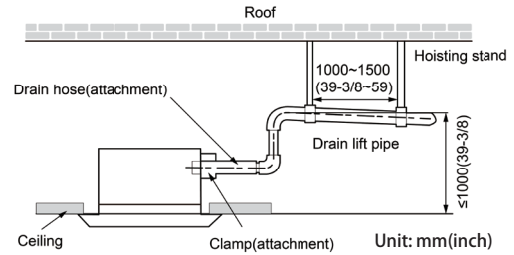

Fig.24

(2). Secure a downward gradient of 1/100 or more for the drain pipe. To accomplish this, mount supporting brackets at an interval of 1 -1.5 m.

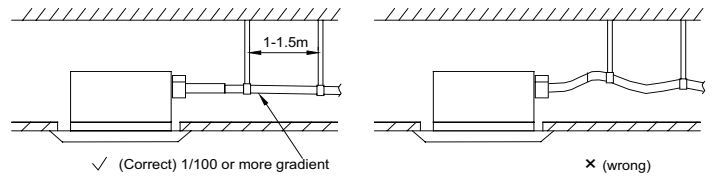

Fig.25

(3). The incline of attached drain hose should be 75 mm or less so that the drain outlet does not have to withstand additional force.

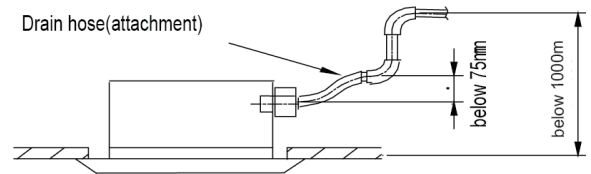

Fig.26

8.5.4 Check Drainage

After the pipeline work is finished, check whether the drainage can go smoothly.

(1). Add slowly about 1L of water into the water tray. After the electric circuit is completed, check the drainage condition during refrigerating operation.

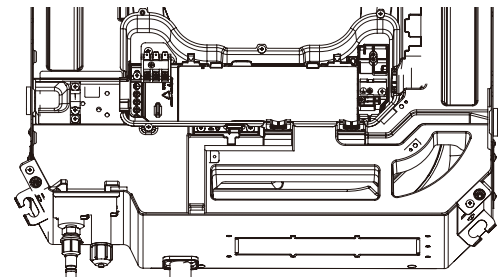

Fig.27

Single-phase units(12~24k)

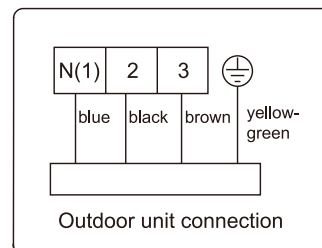
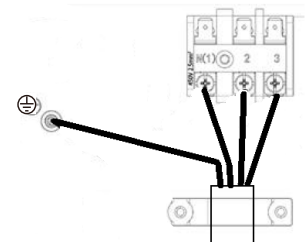

Fig.28



8. Installation

8.6 Installing the Front Panel

As shown below, take off the 4 corner covers from the front panel and loose the hexagon screw bolts on the 4 fasteners to the maximum. The position marked with "PIPING SIDE" on the front panel will direct right at the pipe mouth of the indoor unit.

- (1) Temporarily hang the 4 fasteners on the corresponding hooks of the main body of the indoor unit (Do not let the conducting wires get involved into the sealing material).
- (2) Screw in the hexagon screws beneath the 4 fasteners by about 15mm (Front panel will rise).
- (3) As shown below, turn the front panel according to the arrow direction so that the front panel can be well connected with the ceiling.
- (4) Screw up the screws until the thickness of the sealing material between the front panel and the ceiling is 5-8mm.

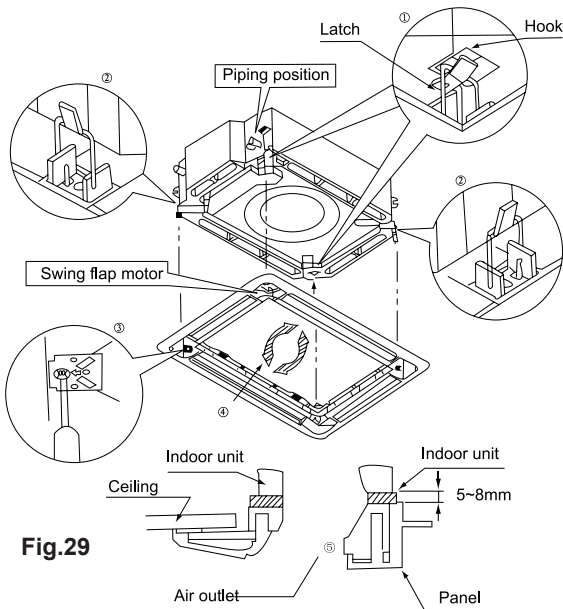

Fig.29

NOTES:

- (1) Improper screw looseness will lead to the following problem.

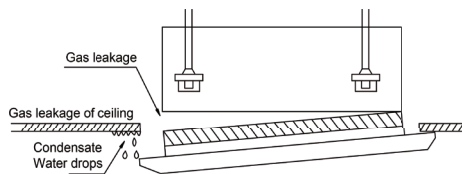

Fig.30

- (2) After the screws are tightened, if there is still a gap between the ceiling and the decorative front panel, adjust the height of the unit again (as shown below).

If the lifting level of indoor unit and the drain pipeline won't be affected, it's fine to adjust the height of indoor unit through the holes on the corners of the front panel.

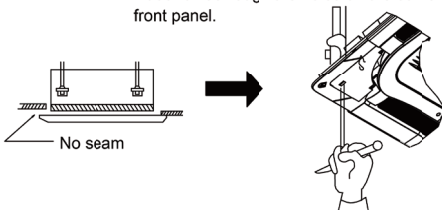

Fig.31

- (3) After installing the front panel, make sure there's no gap between the unit and the front panel.
- (4) Circuit of the decorative front panel.
- (5) Connect the front panel to the main body through the corresponding slots. Match the slots according to their different size.

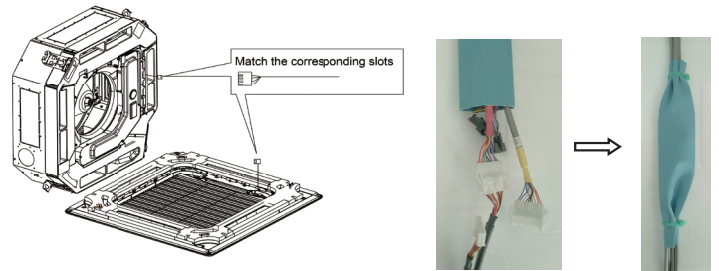

Fig.32

WARNING!

After installing the panel, the insulated protective cover with the thickness of 1mm shall be used to wrap the wiring terminal, Tighten the insulated glue cover on both sides with bonding tie to fix it.

8.7 Electrical Wiring

8.7.1 Wiring Precautions

WARNING!

- ① . Before obtaining access to terminals, all supply circuits must be disconnected.
- ② . The rated voltage of the unit is as shown as Table 4
- ③ . Before turning on, verify that the voltage is within the 198~264V range(for single phase unit) or 342~457V range (for three-phase unit).
- ④ . Always use a special branch circuit and install a special receptacle to supply power to the air conditioner.
- ⑤ . The special branch circuit breaker is installed in the permanent wiring. Always use a circuit that can trip all the poles of the wiring and has an isolation distance of at least 3mm between the contacts of each pole.
- ⑥ . Perform wiring work in accordance with standards so that the air conditioner can be operated safely and positively.
- ⑦ . Install a leakage special branch circuit breaker in accordance with the related laws and regulations and electric company standards.

CAUTION!

- ① . The power source capacity must be the sum of the air conditioner current and the current of other electrical appliances. When the current contracted capacity is insufficient, change the contracted capacity.
- ② . When the voltage is low and the air conditioner is difficult to start, contact the power company to raise the voltage.

8.7.2 Electrical Wiring

- (1) For solid core wiring (Fig.33)
 - 1). Cut the wire end with a wire cutter or wire-cutting pliers, then strip the insulation about 25 mm (15/16") .
 - 2). Using a screwdriver, remove the terminal screw(s) on the terminal board.
 - 3). Using pliers, bend the solid wire to form a loop suitable for the terminal screw.
 - 4). Shape the loop wire properly, place it on the terminal board and tighten securely with the terminal screw using a screwdriver.

8. Installation

(2). For strand wiring (Fig.33)

- 1). Cut the wire end with a wire cutter or wire-cutting pliers, then strip the insulation about 10 mm (3/8").
- 2). Using a screwdriver, remove the terminal screw (s) on the terminal board.
- 3). Using a round terminal fastener or pliers, securely clamp a round terminal to each stripped wire end.
- 4). Position the round terminal wire, and replace and tighten the terminal screw with a screwdriver.(Fig.34

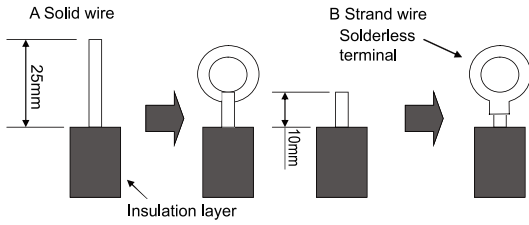

Fig.33

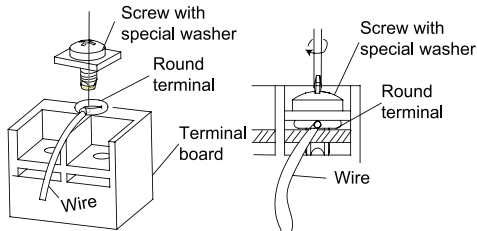

Fig.34

- (3). How to fix connection cord and power cord by cord clamp
After passing the connection cord fasten it with the cord clamp.
(Fig.35

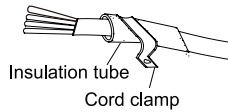

Fig.35

WARNING!

- ① . Before starting work, check that power is not being supplied to the indoor unit and outdoor unit.
- ② . Match the terminal block numbers and connection cord colors with those of the indoor unit side.
- ③ . Erroneous wiring may cause burning of the electric parts.
- ④ . Connect the connection cords firmly to the terminal block. Imperfect installation may cause a fire.
- ⑤ . Always fasten the outside covering of the connection cord with cord clamps. (If the insulator is not clamped, electric leakage may occur.)
- ⑥ . Always connect the ground wire.

(4). Electric wiring of indoor unit side

Take off the electric box cover from the sub-assembly of electric box. Then connect the wires.

Connect the connection wires of indoor unit according to the corresponding marks.

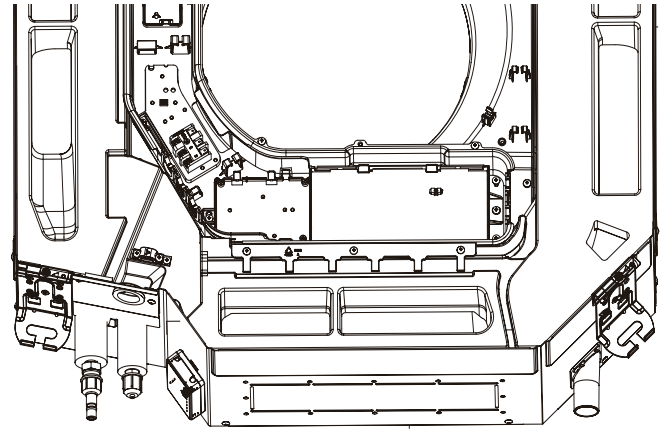

Fig.36

CAUTION!

- ① . Tighten the power cord respectively on the terminal boards with screws. Faulty connection may cause a fire.
- ② . If the power supply are wired incorrectly, the air conditioner may be damaged.
- ③ . Connect the indoor unit connection cord properly based on the corresponding marks as shown in Fig.34.
- ④ . Ground both the indoor and outdoor units by attaching a ground wire.
- ⑤ . Unit shall be grounded in compliance with the applicable local and national codes.

8.8 Installation of Contrrollers

Refer to the Installation Manual of the controller for more details.

8.9 Test Running

8.9.1 Trial Operation and Testing

- (1). The meaning of error codes as shown below:

9. Maintenance

9.1 Error Code List

NO.	Name of malfunction	Indoor unit displaying method				AC status	Malfunctions
		Double 8 code display	Indicator display(LED blinks 0.5s-ON/0.5s-OFF)				
			Running LED	Cooling LED	Heating LED		
1	Indoor and outdoor units communication malfunction	E6	Off 3s blink 6 times			Cooling,compressor will stop,indoor fan motor works,Heating:all will stop	Please refer to troubleshooting
2	Indoor unit motor no feedback	H6	Off 3s blink 11 times			Whole unit will stop to run	1.Poor insert for GPF 2.Indoor control board AP1 malfunction 3.Indoor motor M1 malfunction
3	Jump wire cap malfunction protection	C5	Off 3s blink 15 times			Whole unit will stop to run	Indoor control board AP1 jump cap poor connected,please reinsert or replace the jump cap.
4	Indoor ambient sensor open circuit,short circuit	F1		Off 3s blink once		Cooling,dehumidifying:indoor fan motor is runing,other overloads will stop;Heating,whole unit will stop to run.	1.Room temp.sensor is not connected with the control panel AP1 2.Room temp.sensor is damaged
5	Indoor evaporator sensor circuit open,short circuit	F2		Off 3s blink twice		Cooling,dehumidifying;indoor fan motor runing,other overload will stop;Heating,whole unit will stop.	1,Tube temp.sensor is not connected with the control panel AP1 2.Tube temp.sensor is damaged
6	In defect of refrigerant	F0				The Dual-8 Code Display will show F0 and the complete unit stops.	1. In defect of refrigerant; 2. Indoor evaporator temperature sensor works abnormally; 3. The unit has been plugged up somewhere.
7	Full water protection	E9				Water level switch	If cut-off of water level switch is detected for 8s successively once energized, the system will enter full water protection. In this case, switch off the unit and then switch it on to eliminate this malfunction.

9. Maintenance

9.2 Procedure of Troubleshooting

1. Malfunction of Temperature Sensor F1, F2

Main detection points:

- Is the wiring terminal between the temperature sensor and the controller loosened or poorly contacted?
- Is there short circuit due to trip-over of the parts?
- Is the temperature sensor broken?
- Is mainboard broken?

Malfunction diagnosis process:

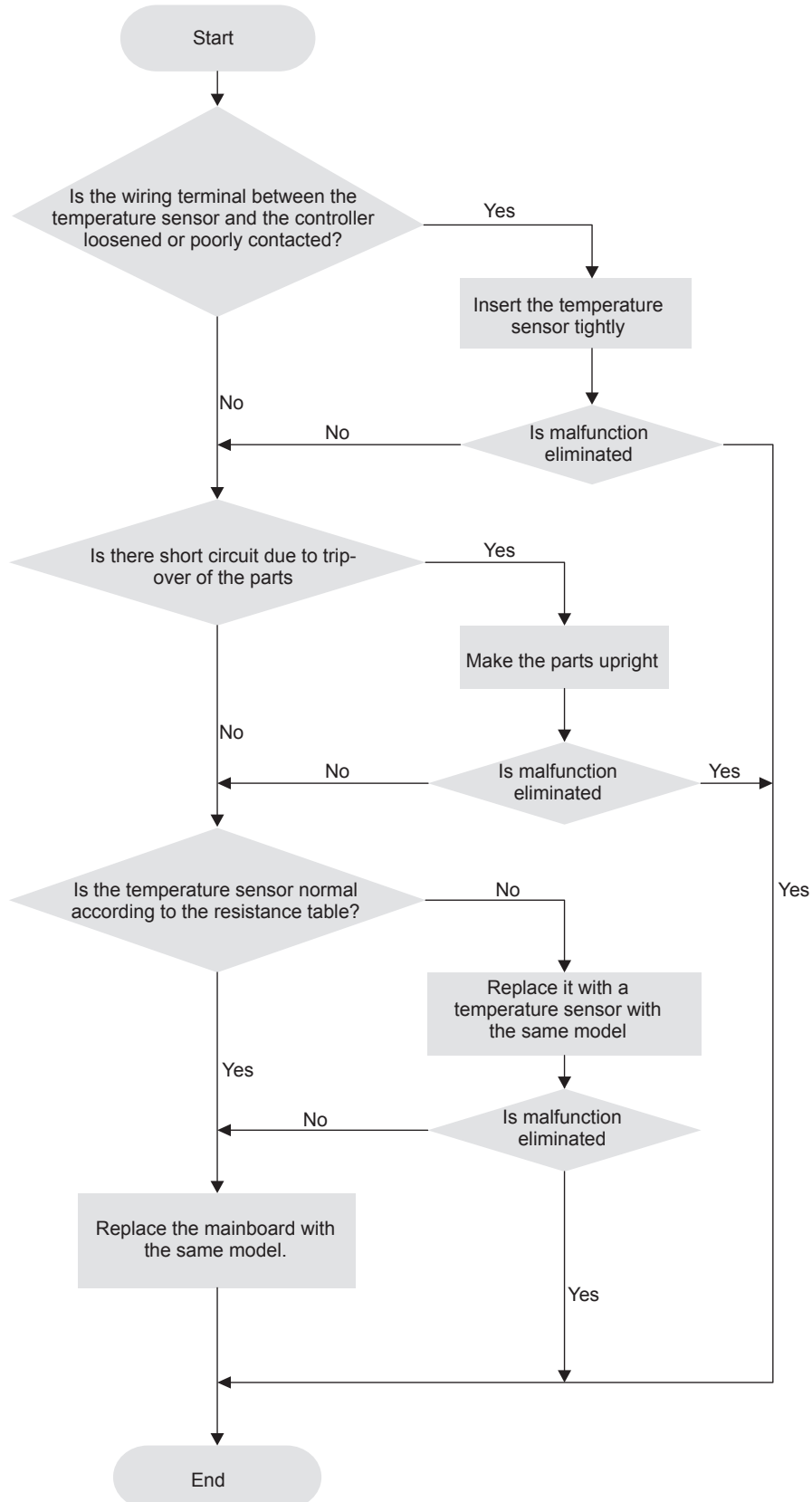

9. Maintenance

2. Malfunction of Blocked Protection of IDU Fan Motor H6

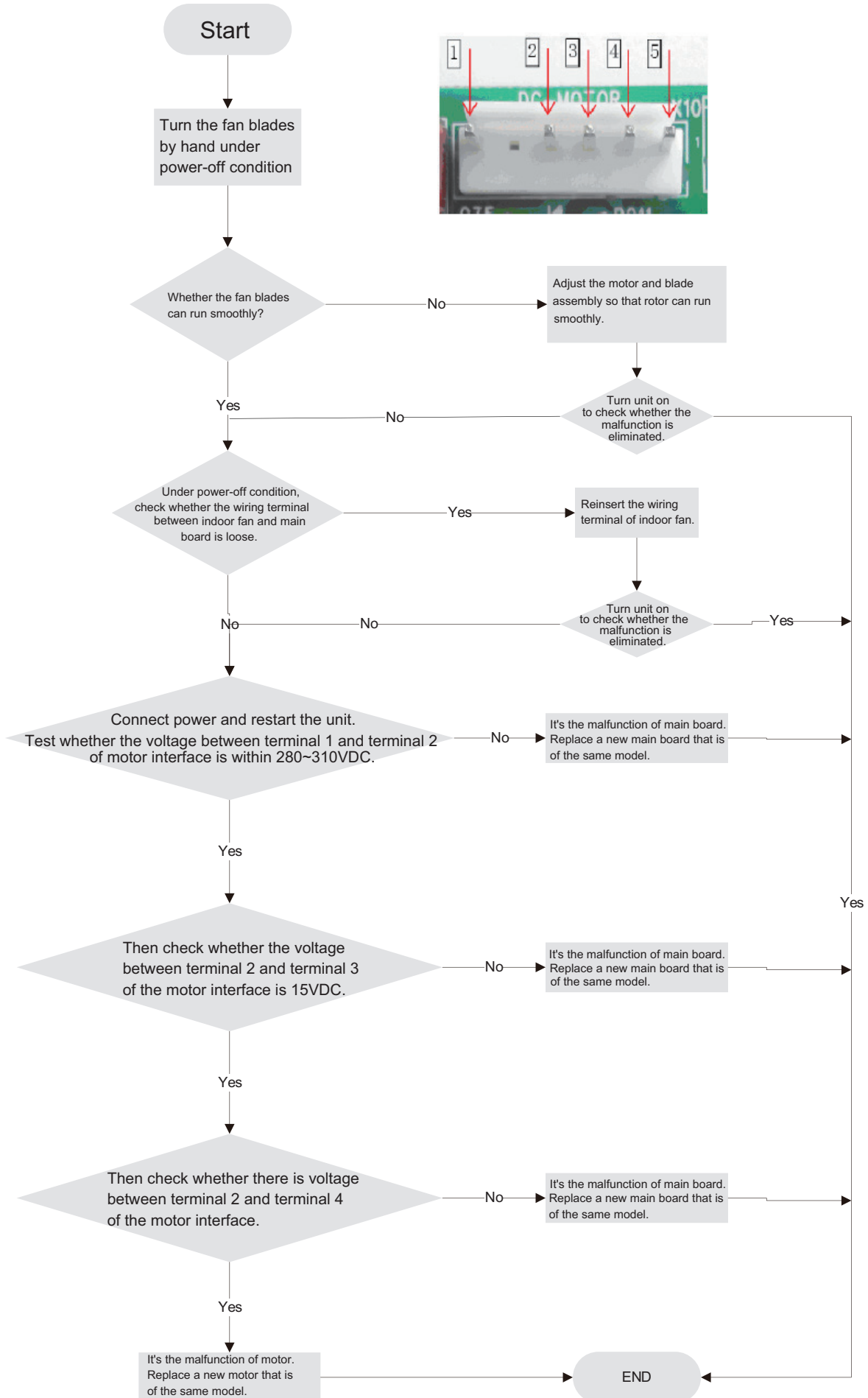

9. Maintenance

3. Malfunction of Protection of Jumper Cap C5

Main detection points:

- Is there jumper cap on the mainboard?
- Is the jumper cap inserted correctly and tightly?
- The jumper is broken?
- The motor is broken?
- Detection circuit of the mainboard is defined abnormal?

Malfunction diagnosis process:

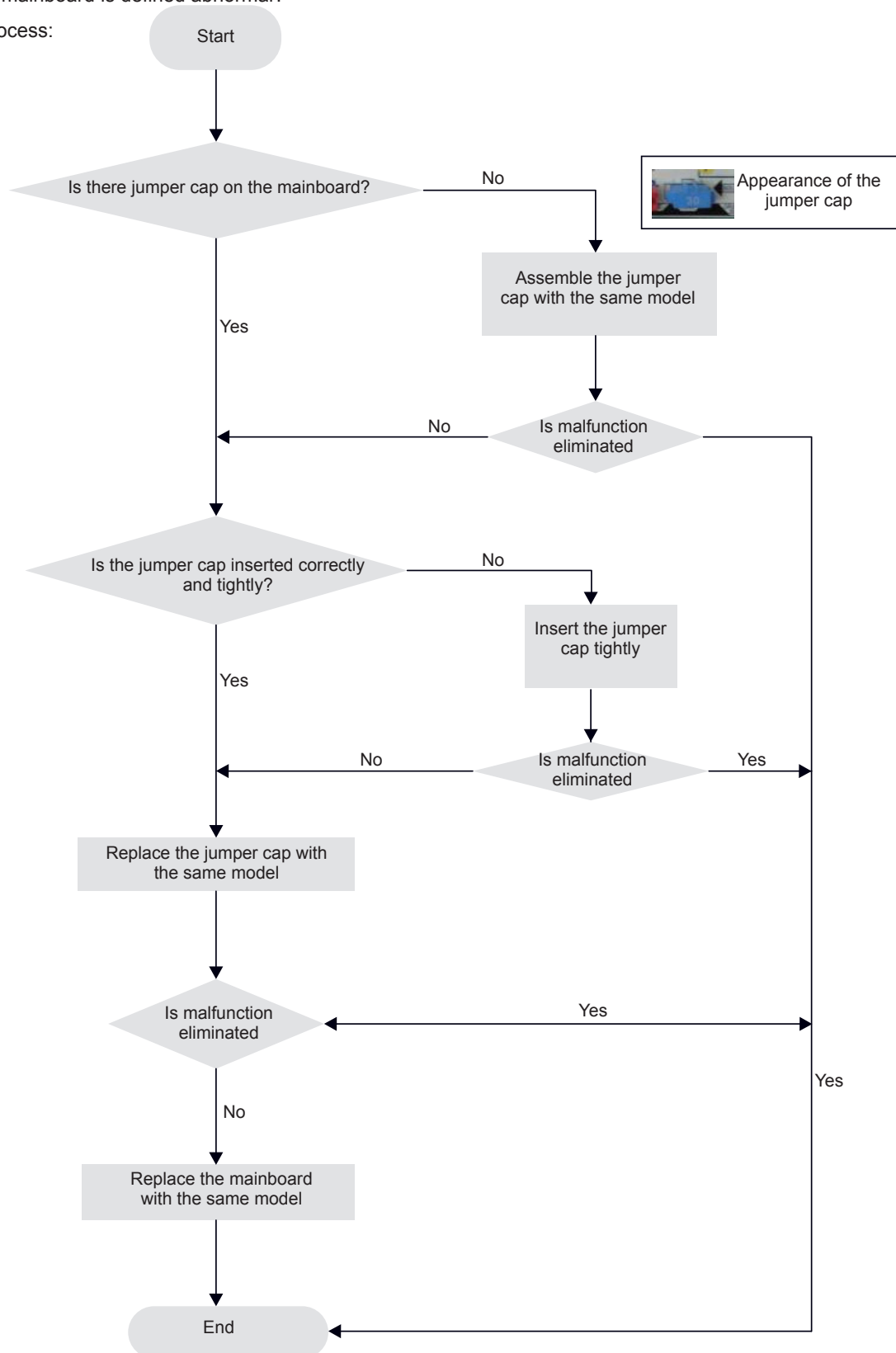

Appearance of the jumper cap

9. Maintenance

4. Communication malfunction E6

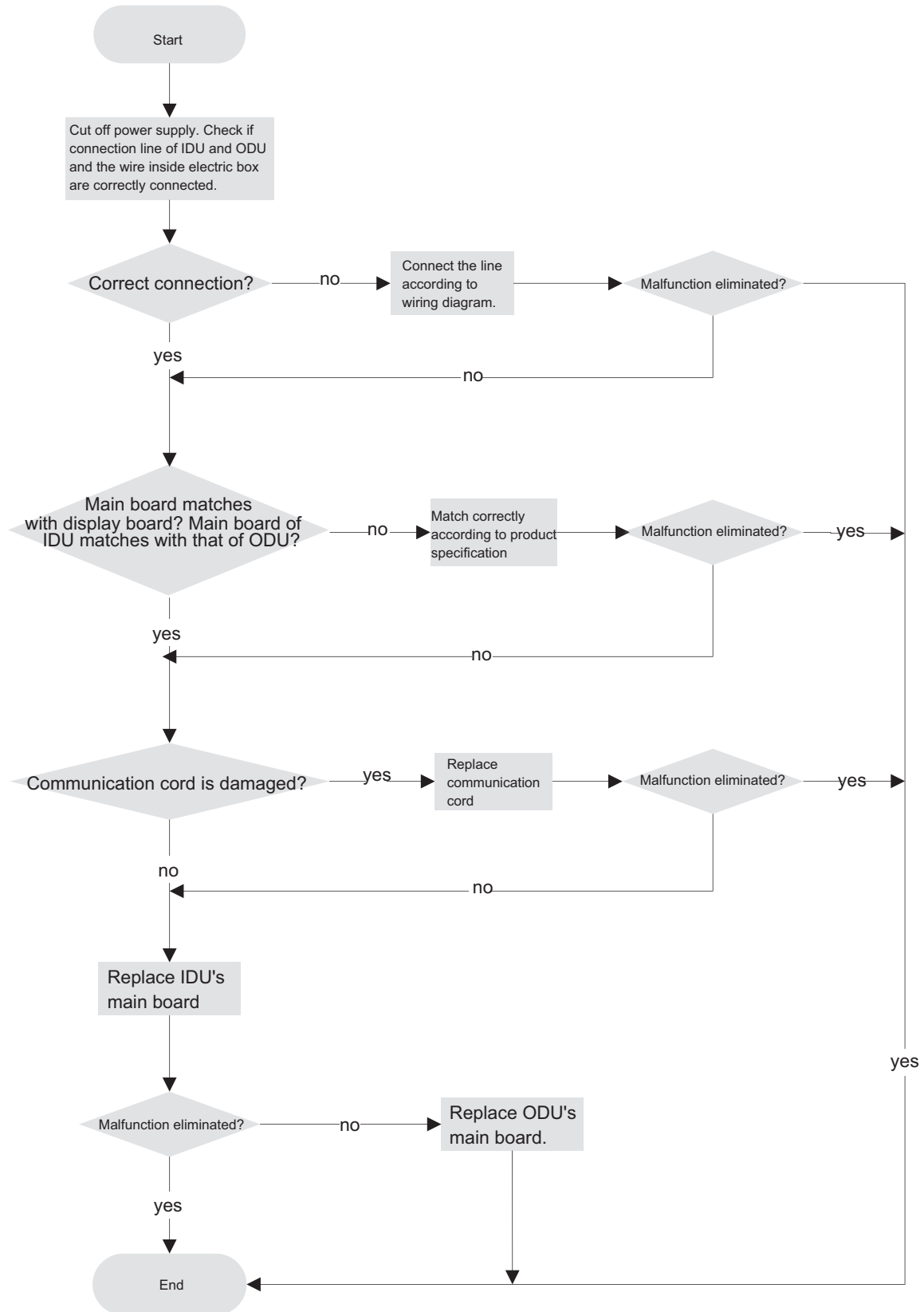

9. Maintenance

5. Malfunction of Insufficient fluorine protection F0

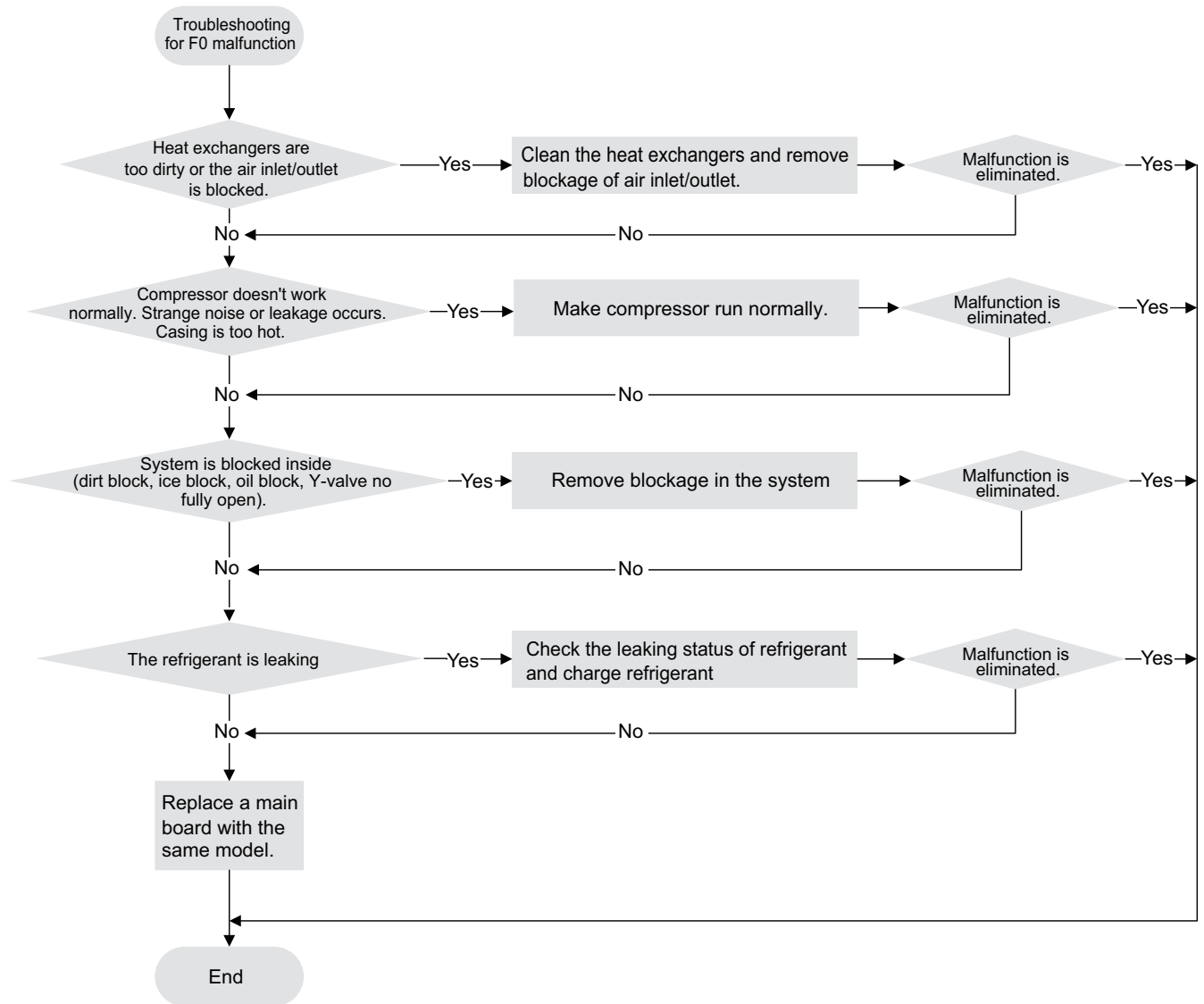

9. Maintenance

6. Full Water Protection E9

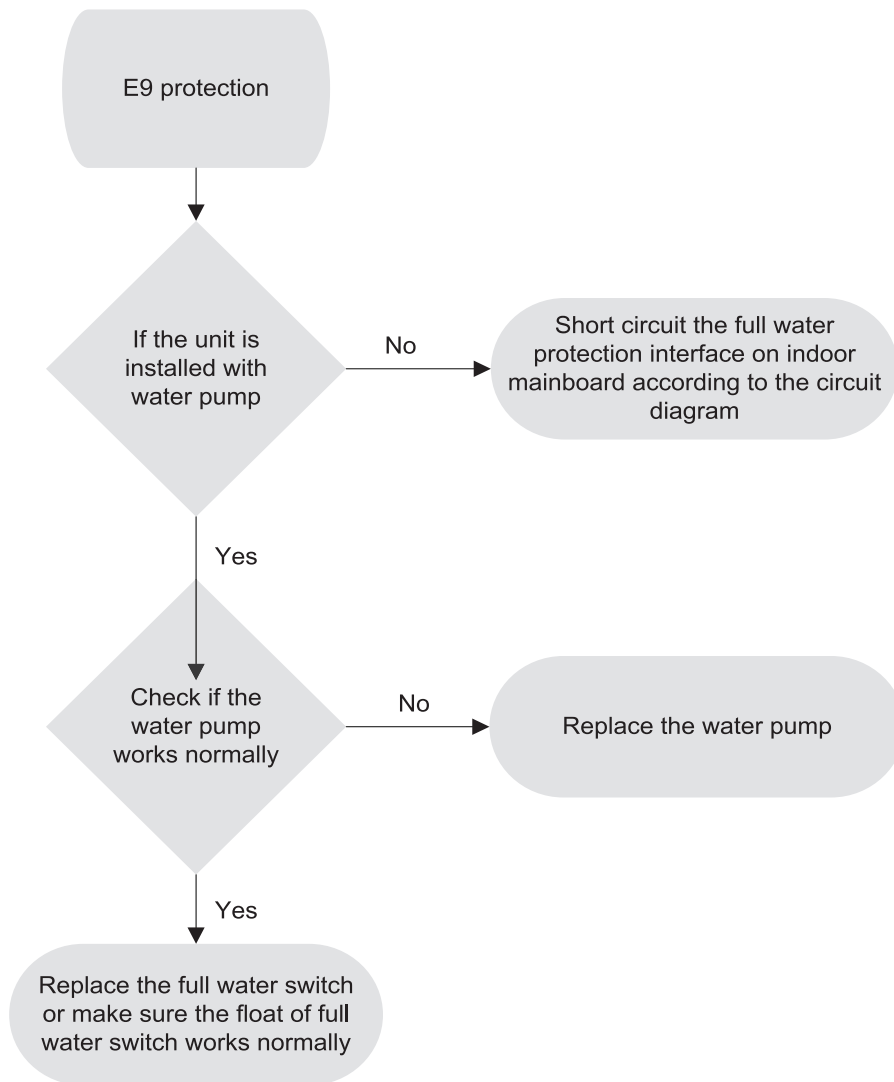

9. Maintenance

9.3 Troubleshooting for Normal Malfunction

1. Air Conditioner Can't be Started Up

Possible Causes	Discriminating Method (Air conditioner Status)	Troubleshooting
No power supply, or poor connection for power plug	After energization, operation indicator isn't bright and the buzzer can't give out sound	Confirm whether it's due to power failure. If yes, wait for power recovery. If not, check power supply circuit and make sure the power plug is connected well.
Wrong wire connection between indoor unit and outdoor unit, or poor connection for wiring terminals	Under normal power supply circumstances, operation indicator isn't bright after energization	Check the circuit according to circuit diagram and connect wires correctly. Make sure all wiring terminals are connected firmly
Electric leakage for air conditioner	After energization, room circuit breaker trips off at once	Make sure the air conditioner is grounded reliably Make sure wires of air conditioner are connected correctly Check the wiring inside air conditioner. Check whether the insulation layer of power cord is damaged; if yes, place the power cord.
Model selection for air switch is improper	After energization, air switch trips off	Select proper air switch
Malfunction of remote controller	After energization, operation indicator is bright, while no display on remote controller or buttons have no action.	Replace batteries for remote controller Repair or replace remote controller

2. Poor Cooling (Heating) for Air Conditioner

Possible Causes	Discriminating Method (Air conditioner Status)	Troubleshooting
Set temperature is improper	Observe the set temperature on remote controller	Adjust the set temperature
Rotation speed of the IDU fan motor is set too low	Small wind blow	Set the fan speed at high or medium
Filter of indoor unit is blocked	Check the filter to see if it's blocked	Clean the filter
Installation position for indoor unit and outdoor unit is improper	Check whether the installation position is proper according to installation requirement for air conditioner	Adjust the installation position, and install the rainproof and sunproof for outdoor unit
Refrigerant is leaking	Discharged air temperature during cooling is higher than normal discharged wind temperature; Discharged air temperature during heating is lower than normal discharged wind temperature; Units pressure is much lower than regulated range	Find out the leakage causes and deal with it. Add refrigerant.
Malfunction of 4-way valve	Blow cold wind during heating	Replace the 4-way valve
Malfunction of capillary	Discharged air temperature during cooling is higher than normal discharged wind temperature; Discharged air temperature during heating is lower than normal discharged wind temperature; Unit pressure is much lower than regulated range. If refrigerant isn't leaking, part of capillary is blocked	Replace the capillary
Flow volume of valve is insufficient	The pressure of valves is much lower than that stated in the specification	Open the valve completely
Malfunction of horizontal louver	Horizontal louver can't swing	Refer to point 3 of maintenance method for details
Malfunction of the IDU fan motor	The IDU fan motor can't operate	Refer to troubleshooting for H6 for maintenance method in details
Malfunction of the ODU fan motor	The ODU fan motor can't operate	Refer to point 4 of maintenance method for details
Malfunction of compressor	Compressor can't operate	Refer to point 5 of maintenance method for details

3. Horizontal Louver Can't Swing

Possible Causes	Discriminating Method (Air conditioner Status)	Troubleshooting
Wrong wire connection, or poor connection	Check the wiring status according to circuit diagram	Connect wires according to wiring diagram to make sure all wiring terminals are connected firmly
Stepping motor is damaged	Stepping motor can't operate	Repair or replace stepping motor
Main board is damaged	Others are all normal, while horizontal louver can't operate	Replace the main board with the same model

9. Maintenance

4. ODU Fan Motor Can't Operate

Possible causes	Discriminating method (air conditioner status)	Troubleshooting
Wrong wire connection, or poor connection	Check the wiring status according to circuit diagram	Connect wires according to wiring diagram to make sure all wiring terminals are connected firmly
Capacity of the ODU fan motor is damaged	Measure the capacity of fan capacitor with an universal meter and find that the capacity is out of the deviation range indicated on the nameplate of fan capacitor.	Replace the capacity of fan
Power voltage is a little low or high	Use universal meter to measure the power supply voltage. The voltage is a little high or low	Suggest to equip with voltage regulator
Motor of outdoor unit is damaged	When unit is on, cooling/heating performance is bad and ODU compressor generates a lot of noise and heat.	Change compressor oil and refrigerant. If no better, replace the compressor with a new one

5. Compressor Can't Operate

Possible causes	Discriminating method (air conditioner status)	Troubleshooting
Wrong wire connection, or poor connection	Check the wiring status according to circuit diagram	Connect wires according to wiring diagram to make sure all wiring terminals are connected firmly
Capacity of compressor is damaged	Measure the capacity of fan capacitor with an universal meter and find that the capacity is out of the deviation range indicated on the nameplate of fan capacitor.	Replace the compressor capacitor
Power voltage is a little low or high	Use universal meter to measure the power supply voltage. The voltage is a little high or low	Suggest to equip with voltage regulator
Coil of compressor is burnt out	Use universal meter to measure the resistance between compressor terminals and its 0	Repair or replace compressor
Cylinder of compressor is blocked	Compressor Can't operate	Repair or replace compressor

6. Air Conditioner is Leaking

Possible causes	Discriminating method (air conditioner status)	Troubleshooting
Drain pipe is blocked	Water leaking from indoor unit	Eliminate the foreign objects inside the drain pipe
Drain pipe is broken	Water leaking from drain pipe	Replace drain pipe
Wrapping is not tight	Water leaking from the pipe connection place of indoor unit	Wrap it again and bundle it tightly

7. Abnormal Sound and Vibration

Possible causes	Discriminating method (air conditioner status)	Troubleshooting
When turn on or turn off the unit, the panel and other parts will expand and theres abnormal sound	Theres the sound of "PAPA"	Normal phenomenon. Abnormal sound will disappear after a few minutes.
When turn on or turn off the unit, theres abnormal sound due to flow of refrigerant inside air conditioner	Water-running sound can be heard	Normal phenomenon. Abnormal sound will disappear after a few minutes.
Foreign objects inside the indoor unit or therere parts touching together inside the indoor unit	Theres abnormal sound fro indoor unit	Remove foreign objects. Adjust all parts position of indoor unit, tighten screws and stick damping plaster between connected parts
Foreign objects inside the outdoor unit or therere parts touching together inside the outdoor unit	Theres abnormal sound fro outdoor unit	Remove foreign objects. Adjust all parts position of outdoor unit, tighten screws and stick damping plaster between connected parts
Short circuit inside the magnetic coil	During heating, the way valve has abnormal electromagnetic sound	Replace magnetic coil
Abnormal shake of compressor	Outdoor unit gives out abnormal sound	Adjust the support foot mat of compressor, tighten the bolts
Abnormal sound inside the compressor	Abnormal sound inside the compressor	If add too much refrigerant during maintenance, please reduce refrigerant properly. Replace compressor for other circumstances.

10. Exploded View and Parts List

CHML-IC12RK2 CHML-IC18RK2

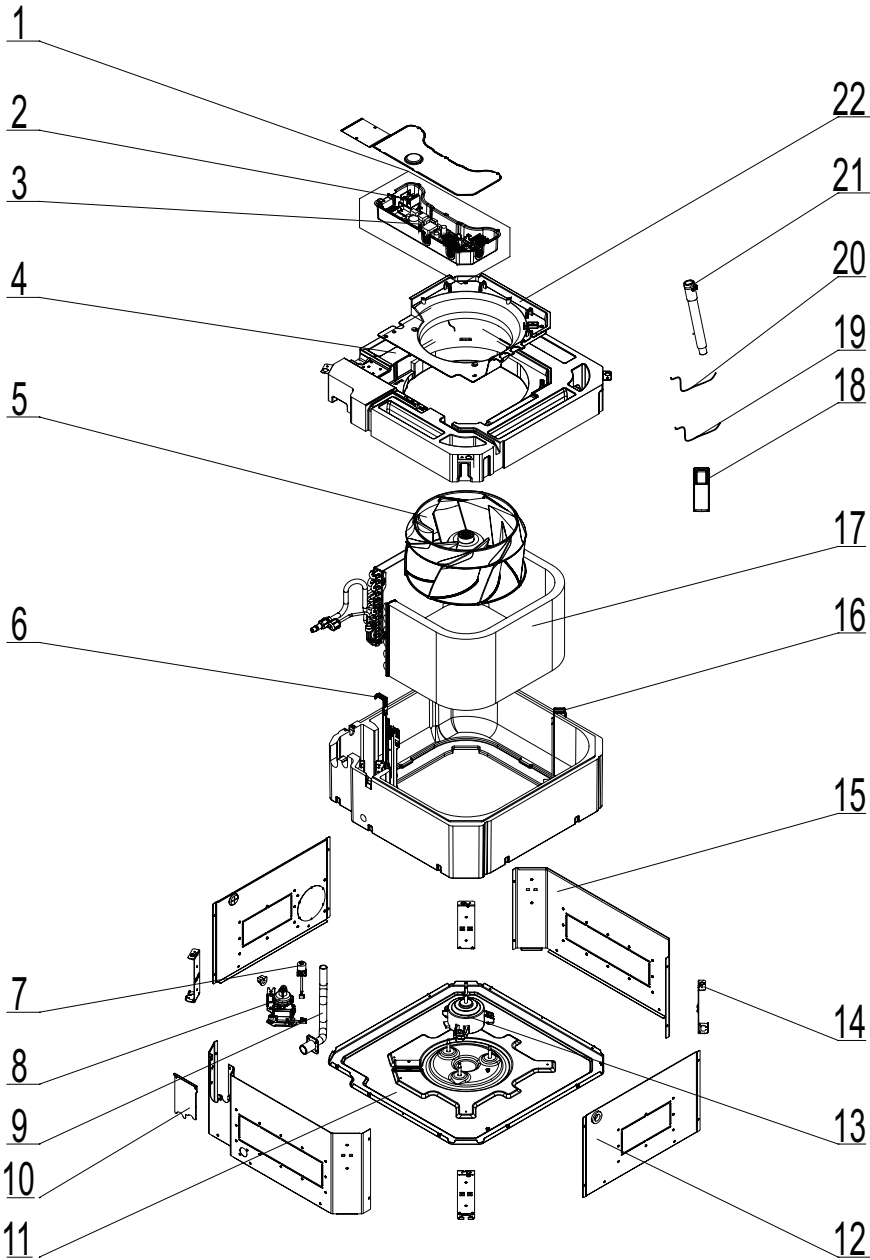

The component picture is only for reference; please refer to the actual product.

10. Exploded View and Parts List

NO.	Description	Part Code		Qty
		CHML-IC12RK2	CHML-IC18RK2	
		Product Code	Product Code	
1	Electric Box Assy	100002071502	100002071509	1
2	Terminal Board	422000060015	422000060015	1
3	Main Board	300002061959	300002061959	1
4	Water Tray Assy	000069060065	000069060065	1
5	Centifugal Fan	103003060008	103003060008	1
6	Connection Sheet Sub-Assy	017025060047	017025060047	1
7	Water Level Switch	430024000005	430024000005	1
8	Water Pump	4313800005802	4313800005802	1
9	Drain Pipe	200070060005	200070060005	1
10	Sealplate	012034060119	012034060119	1
11	Seat Board Sub-Assy	017080060023	017080060023	1
12	Side Plate	01201006017701	01201006017701	1
13	Brushless DC Motor	150104060012	150104060012	1
14	Mounting Rack Sub-Assy	017044060011	017044060011	1
15	Side Plate	012010060175	012010060175	1
16	Support	012060061048	012060061048	1
17	Evaporator Assy	011001061552	011001061552	1
18	Remote Control	305001060060	305001060060	1
19	Room Sensor	39000191	39000191	1
20	Temperature Sensor	390001921	390001921	1
21	Drain Hose Sub-Assy	007008000001	007008000001	1
22	Flow Guide Loop	200150060003	200150060003	1

Above data is subject to change without notice.

10. Exploded View and Parts List

CHML-IC24RK2

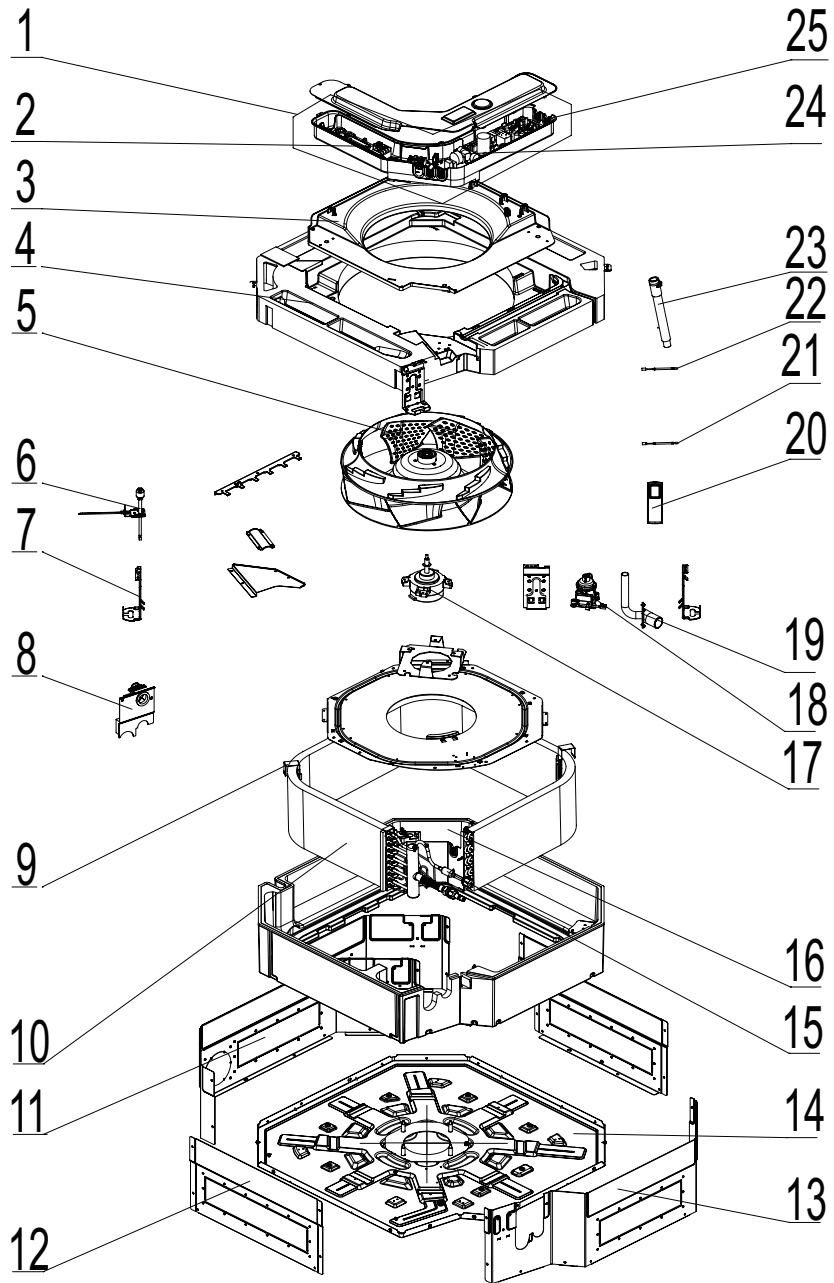

The component picture is only for reference; please refer to the actual product.

10. Exploded View and Parts List

NO.	Description	Part Code		Qty
		CHML-IC24RK2		
		CN510N0300		
1	Electric Box Assy	100002071503		1
2	Terminal Board	42000100000207		1
3	Diversion Circle	26909400067		1
4	Water Tray Assy	000069060008		1
5	Centrifugal Fan	10429400004		1
6	Liquid Level Switch	4502021601		1
7	Body Installing Plate	01332701		1
8	Seal plate Assy	01499400003		1
9	Fixed Mount	0184940002001P		1
10	Evaporator Assy	011001000254		1
11	Side Plate 1	01319400049		1
12	Side Plate 3	01319400051		1
13	Side Plate 2	01319400050		1
14	Seat Board Sub-Assy	02229400011		1
15	Strainer	07213050		1
16	Support	01809400052		1
17	Brushless DC Motor	1570410000702		1
18	Water Pump	43138000058		1
19	Drainage Pipe Sub-Assy	26909400055		1
20	Remote Controller	305001060060		1
21	Temperature Sensor	390000453		1
22	Temperature Sensor	39000286		1
23	Drain Hose Sub-Assy	05232702		1
24	Filter Board	30221000021		1
25	Main Board	300002062052		1

Above data is subject to change without notice.

11. Removal Procedure

 **Caution: discharge the refrigerant completely before removal.**

Removal of fan and motor

Note: Before removing the motor, power must be cut off.

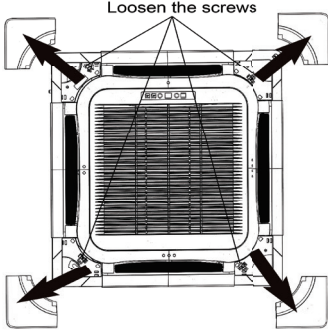
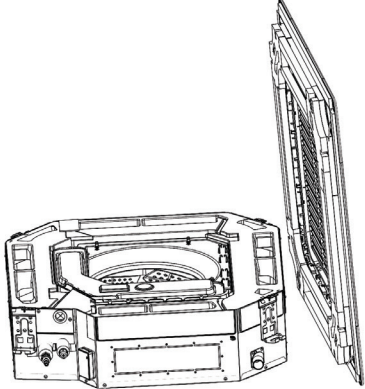
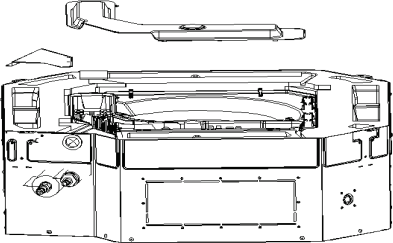
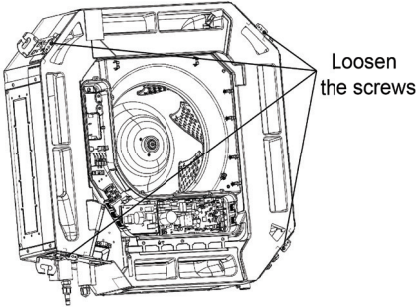
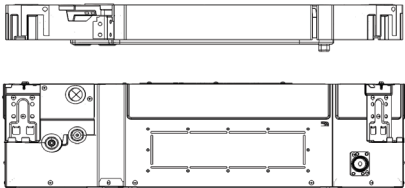
Step	Picture	Work instruction
1. Remove the front panel.	 	<ul style="list-style-type: none"> ● Turn off the power supply of indoor unit. ● Push the 4 corner plates in the directions shown by the arrows. ● Loosen the screws and remove the front panel.
2. Remove the cover of electric box and the clamp of power cord.		<ul style="list-style-type: none"> ● Remove the motor wire and water pump of the electric box.
3. Remove the water tray.	 	<ul style="list-style-type: none"> ● Loosen the screws in the 4 corners and then remove the water tray.

11. Removal Procedure

Removal of fan and motor

Note: Before removing the motor, power must be cut off.

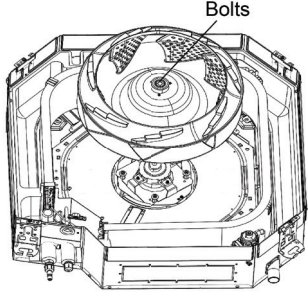
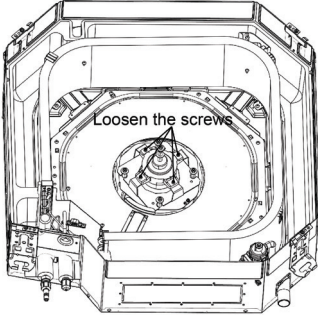
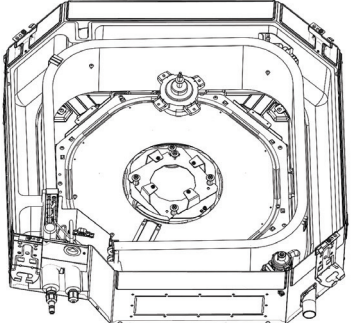
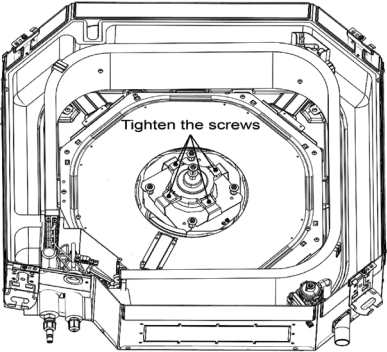
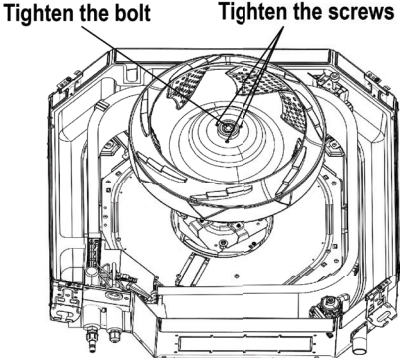
Step	Picture	Work instruction
4. Remove the fan.		<ul style="list-style-type: none"> ● Use a screwdriver to remove the clamping band of motor. Then remove the fan.
5. Remove motor.		<ul style="list-style-type: none"> ● Use a screwdriver to unscrew the 4 screws of motor. Then remove the motor.
		
6. Replace and install the motor.		<ul style="list-style-type: none"> ● Remove the motor from motor support and then replace with a new motor. ● Tighten the 4 screws of motor with a screwdriver.
7. Install the fan.		<ul style="list-style-type: none"> ● Direct the hole of fan to the motor shaft and then mount on the fan. ● Tighten the clamping band of motor with a wrench.

11. Removal Procedure

Removal of fan and motor

Note: Before removing the motor, power must be cut off.

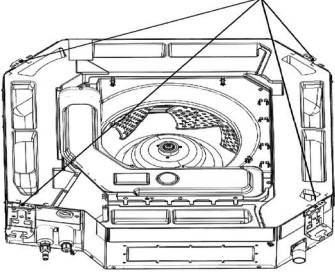
Step	Picture	Work instruction
8. Install the water tray.	<p style="text-align: center;">Tighten the screws</p> 	<ul style="list-style-type: none"> ● Direct the 4 corners of water tray to the 4 corners of the unit and then press them. Use a screwdriver to tighten the screws in the 4 corners. ● Connect the power cord and water pump wire. ● Place back the cover of electric box and the clamp of power cord. Then tighten the screws with a screwdriver.

Removal and installation of drain pump

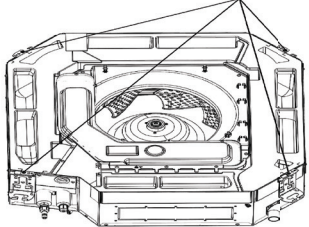
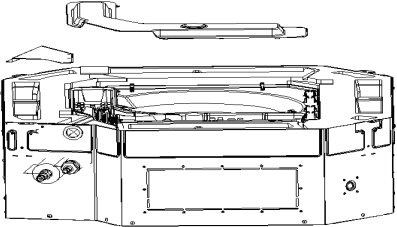
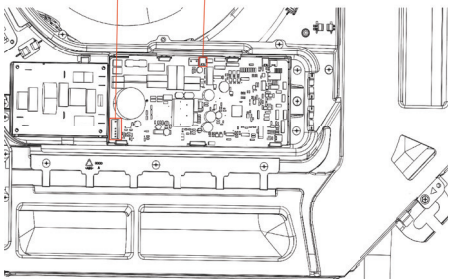
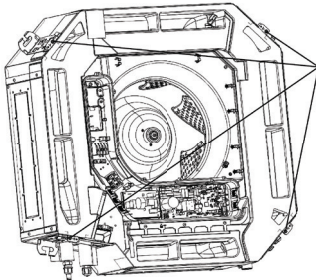
Step	Picture	Work instruction
1. After removing the front panel as instructed above, loosen the screws of the water tray.	<p style="text-align: center;">Loosen the screws</p> 	<ul style="list-style-type: none"> ● Use a screwdriver to loosen the screws of water tray.
2. Remove the cover of electric box and the clamp of power cord.		<ul style="list-style-type: none"> ● Twist off the screws and open the cover of electric box and the clamp of power cord.
3. Remove the motor wire and water pump wire.	<p style="text-align: center;">Motor wiring port Pump wiring port</p> 	<ul style="list-style-type: none"> ● Remove the motor wire and water pump wire in the electric box.
4. Remove the water tray.	<p style="text-align: right;">Loosen the screws</p> 	<ul style="list-style-type: none"> ● Loosen the screws in the 4 corners and then remove the water tray.

11. Removal Procedure

Removal and installation of drain pump		
Step	Picture	Work instruction
5. Remove the drain pipe and loosen the screws of water pump.		<ul style="list-style-type: none"> ● Take out the drain pipe and use a screwdriver to loosen the screws of water pump.
6. Remove and replace the pump.		<ul style="list-style-type: none"> ● Remove the pump and replace with a new one.
7. Connect the drain pipe and tighten the screws of water pump.		<ul style="list-style-type: none"> ● Connect the drain pipe and tighten the screws of water pump.
8. Install the water tray and tighten the screws.		<ul style="list-style-type: none"> ● Direct the 4 corners of the water tray to the 4 corners of the unit and press them. Then use a screwdriver to tighten the screws.
9. Connect the water pump wire and power cord, and then put back the cover of electric box and the clamp of power cord.		<ul style="list-style-type: none"> ● Connect the water pump wire and motor wire according to the wiring diagram. ● Put back the cover of electric box and the clamp of power cord. Then tighten the screws.

Appendix

Appendix 1: Reference Sheet of Celsius and Fahrenheit

Conversion formula for Fahrenheit degree and Celsius degree: $T_f = T_c \times 1.8 + 32$

Set temperature

Fahrenheit display temperature (°F)	Fahrenheit (°F)	Celsius (°C)	Fahrenheit display temperature (°F)	Fahrenheit (°F)	Celsius (°C)	Fahrenheit display temperature (°F)	Fahrenheit (°F)	Celsius (°C)
61	60.8	16	69/70	69.8	21	78/79	78.8	26
62/63	62.6	17	71/72	71.6	22	80/81	80.6	27
64/65	64.4	18	73/74	73.4	23	82/83	82.4	28
66/67	66.2	19	75/76	75.2	24	84/85	84.2	29
68	68	20	77	77	25	86	86	30

Ambient temperature

Fahrenheit display temperature (°F)	Fahrenheit (°F)	Celsius (°C)	Fahrenheit display temperature (°F)	Fahrenheit (°F)	Celsius (°C)	Fahrenheit display temperature (°F)	Fahrenheit (°F)	Celsius (°C)
32/33	32	0	55/56	55.4	13	79/80	78.8	26
34/35	33.8	1	57/58	57.2	14	81	80.6	27
36	35.6	2	59/60	59	15	82/83	82.4	28
37/38	37.4	3	61/62	60.8	16	84/85	84.2	29
39/40	39.2	4	63	62.6	17	86/87	86	30
41/42	41	5	64/65	64.4	18	88/89	87.8	31
43/44	42.8	6	66/67	66.2	19	90	89.6	32
45	44.6	7	68/69	68	20	91/92	91.4	33
46/47	46.4	8	70/71	69.8	21	93/94	93.2	34
48/49	48.2	9	72	71.6	22	95/96	95	35
50/51	50	10	73/74	73.4	23	97/98	96.8	36
52/53	51.8	11	75/76	75.2	24	99	98.6	37
54	53.6	12	77/78	77	25			

Appendix 2: Configuration of Connection Pipe

1. Standard length of connection pipe (More details please refer to the specifications.)

2. Min. length of connection pipe is 3m.

3. Max. length of connection pipe and max. high difference. (More details please refer to the specifications.)

4. The additional refrigerant oil and refrigerant charging required after prolonging connection pipe

- After the length of connection pipe is prolonged for 10m at the basis of standard length, you should add 5ml of refrigerant oil for each additional 5m of connection pipe.
- The calculation method of additional refrigerant charging amount (on the basis of liquid pipe):
- Basing on the length of standard pipe, add refrigerant according to the requirement as shown in the table. The additional refrigerant charging amount per meter is different according to the diameter of liquid pipe. See the following sheet.
- Additional refrigerant charging amount = prolonged length of liquid pipe X additional refrigerant charging amount per meter

Additional refrigerant charging amount for R32

Diameter of connection pipe		Indoor unit throttl	Outdoor unit throttle	
Liquid pipe	Gas pipe	Cooling only, cooling and heating (g / m)	Cooling only (g/m)	Cooling and heating (g/m)
Φ1/4"	Φ3/8" or Φ1/2"	16	12	16
Φ1/4" or Φ3/8"	Φ5/8" or Φ3/4"	40	12	40
Φ1/2"	Φ3/4" or Φ7/8"	80	24	96
Φ5/8"	Φ1" or Φ1 1/4"	136	48	96
Φ3/4"	/	200	200	200
Φ7/8"	/	280	280	280

Appendix 3: Pipe Expanding Method

⚠ Note:

Improper pipe expanding is the main cause of refrigerant leakage. Please expand the pipe according to the following steps:

A: Cut the pipe

- Confirm the pipe length according to the distance of indoor unit and outdoor unit.
- Cut the required pipe with pipe cutter.

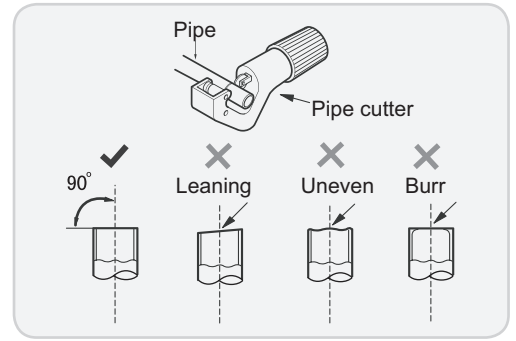

B: Remove the burrs

- Remove the burrs with shaper and prevent the burrs from getting into the pipe.

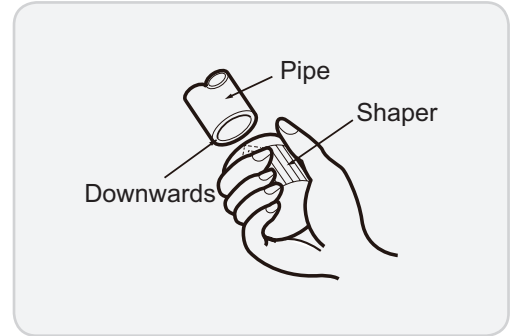

C: Put on suitable insulating pipe.

D: Put on the union nut

- Remove the union nut on the indoor connection pipe and outdoor valve; install the union nut on the pipe.

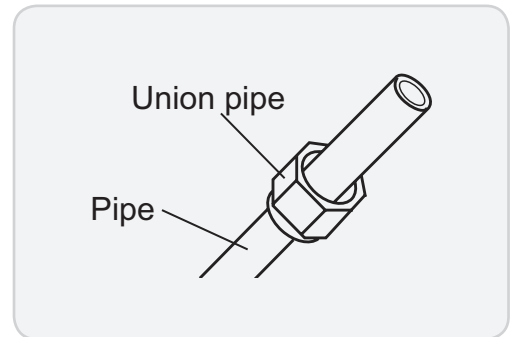

E: Expand the port

- Expand the port with expander.

⚠ Note:

- "A" is different according to the diameter, please refer to the sheet below:

Outer diameter(mm)	A(mm)	
	Max	Min
Φ6 - 6.35 (1/4")	1.3	0.7
Φ9 - Φ9.52 (3/8")	1.6	1.0
Φ12 - 12.70 (1/2")	1.8	1.0
Φ16 - 15.88 (5/8")	2.4	2.2

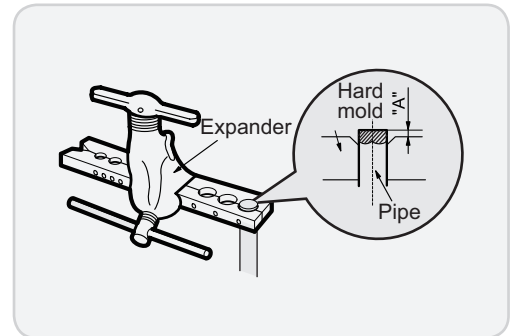

F: Inspection

- Check the quality of expanding port. If there is any blemish, expand the port again according to the steps above.

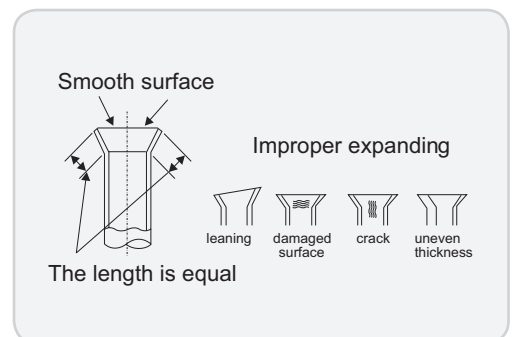

Appendix

Appendix 4: List of Resistance for Temperature Sensor

Resistance Table of Ambient Temperature Sensor for Indoor and Outdoor Units(15K)

Temp(°C)	Resistance(kΩ)
-19	138.10
-18	128.60
-16	115.00
-14	102.90
-12	92.22
-10	82.75
-8	74.35
-6	66.88
-4	60.23
-2	54.31

Temp(°C)	Resistance(kΩ)
0	49.02
2	44.31
4	40.09
6	36.32
8	32.94
10	29.90
12	27.18
14	24.73
16	22.53
18	20.54

Temp(°C)	Resistance(kΩ)
20	18.75
22	17.14
24	15.68
26	14.36
28	13.16
30	12.07
32	11.09
34	10.20
36	9.38
38	8.64

Temp(°C)	Resistance(kΩ)
40	7.97
42	7.35
44	6.79
46	6.28
48	5.81
50	5.38
52	4.99
54	4.63
56	4.29
58	3.99

Resistance Table of Tube Temperature Sensors for Indoor and Outdoor (20K)

Temp(°C)	Resistance(kΩ)
-19	181.40
-15	145.00
-10	110.30
-5	84.61
0	65.37
5	50.87
10	39.87
15	31.47

Temp(°C)	Resistance(kΩ)
20	25.01
25	20.00
30	16.10
35	13.04
40	10.62
45	8.71
50	7.17
55	5.94

Temp(°C)	Resistance(kΩ)
60	4.95
65	4.14
70	3.48
75	2.94
80	2.50
85	2.13
90	1.82
95	1.56

Temp(°C)	Resistance(kΩ)
100	1.35
105	1.16
110	1.01
115	0.88
120	0.77
125	0.67
130	0.59
135	0.52

Resistance Table of Discharge Temperature Sensor for Outdoor(50K)

Temp(°C)	Resistance(kΩ)
-30	911.400
-25	660.8
-20	486.5
-15	362.9
-10	274
-5	209
0	161
5	125.1

Temp(°C)	Resistance(kΩ)
10	98
15	77.35
20	61.48
25	49.19
30	39.61
35	32.09
40	26.15
45	21.43

Temp(°C)	Resistance(kΩ)
50	17.65
55	14.62
60	12.17
65	10.18
70	8.555
75	7.224
80	6.129
85	5.222

Temp(°C)	Resistance(kΩ)
90	4.469
95	3.841
100	3.315
105	2.872
110	2.498
115	2.182
120	1.912
125	1.682

